



XTMT15N70D

150V N-Channel MOSFET

Product Description

BV_{DSS}	150	V
I_D	70	A
$R_{DS(ON),Typ.}$	14	m Ω

General Features

- Proprietary New Planar Technology
- $R_{DS(ON),typ.}=14\text{ m}\Omega@V_{GS}=10V$
- Fast Recovery Body Diode
- Low Gate Charge Minimize Switching Loss

Applications

- Uninterruptible Power Supply
- Power Switching application

封装 Package

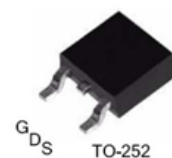
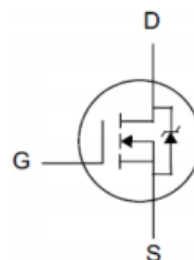

Device	Package	Marking
XTMT15N70D	TO-252	XTMT15N70D

Absolute Maximum Ratings $T_j=25^\circ\text{C}$

Symbol	Parameter	Value	Unit
V_{DSS}	Drain-to-Source Voltage	150	V
V_{GSS}	Gate-to-Source Voltage	± 20	
I_D	Continuous Drain Current	70	A
I_{DM}	Pulsed Drain Current at $V_{GS}=10V$	280	
E_{AS}	Single Pulse Avalanche Energy	500	mJ
P_D	Power Dissipation	310	W
	Derating Factor above 25°C	2.07	W/ $^\circ\text{C}$
T_L	Soldering Temperature Distance of 1.6mm from case for 10 seconds	300	$^\circ\text{C}$
$T_J \& T_{STG}$	Operating and Storage Temperature Range	-55 to 150	

Caution: Stresses greater than those listed in the "Absolute Maximum Ratings" may cause permanent damage to the device.



Thermal Characteristics

Symbol	Parameter	Value	Unit
$R_{\theta JC}$	Thermal Resistance, Junction-to-Case	0.48	$^{\circ}C/W$
$R_{\theta JA}$	Thermal Resistance, Junction-to-Ambient	62.5	$^{\circ}C/W$

Electrical Characteristics $T_j=25^{\circ}C$

OFF Characteristics

Symbol	Parameter	Min	Typ	Max	Unit	Test Condition
BV_{DSS}	Drain-to-Source Breakdown Voltage	150	-	-	V	$V_{GS}=0V, I_D=250\mu A$
I_{DSS}	Drain-to-Source Leakage Current	-	-	1	uA	$V_{DS}=150V, V_{GS}=0V$
		-	-	100		$V_{DS}=120V, V_{GS}=0V, T_J=125^{\circ}C$
I_{GSS}	Gate-to-Source Leakage Current	-	-	+100	nA	$V_{GS}=+20V, V_{DS}=0V$
		-	-	-100		$V_{GS}=-20V, V_{DS}=0V$

ON Characteristics

Symbol	Parameter	Min	Typ	Max	Unit	Test Condition
$R_{DS(ON)}$	Static Drain-to-Source On-Resistance	-	14	18	m Ω	$V_{GS}=10V, I_D=20A$
$V_{GS(TH)}$	Gate Threshold Voltage	2.0	3.0	3.6	V	$V_{DS}=V_{GS}, I_D=250\mu A$
g_{FS}	Forward Transconductance	50			S	$V_{DS}=5V, I_D=20A$

**Dynamic Characteristics**

Symbol	Parameter	Min	Typ	Max	Unit	Test Condition
C_{iss}	Input Capacitance	-	6644	-	pF	$V_{GS}=0V,$ $V_{DS}=75V,$ $f=1.0MHz$
C_{rss}	Reverse Transfer Capacitance	-	178	-		
C_{oss}	Output Capacitance	-	243	-		
R_G	Gate Series Resistance		1.7		Ω	$f=1.0MHz$
Q_g	Total Gate Charge	-	148	-	nC	$V_{DD}=75V,$ $I_D=20A, V_{GS}=10V$
Q_{gs}	Gate-to-Source Charge	-	28	-		
Q_{gd}	Gate-to-Drain (Miller) Charge	-	50	-		

Resistive Switching Characteristics

Symbol	Parameter	Min	Typ	Max	Unit	Test Condition
$t_{d(ON)}$	Turn-on Delay Time	-	28	-	ns	$V_{DD}=75V,$ $I_D=20A,$ $V_{GS}=10V$ $R_g=2.5\Omega$
t_{rise}	Rise Time	-	30	-		
$t_{d(OFF)}$	Turn-Off Delay Time	-	95	-		
t_{fall}	Fall Time	-	40	-		

Source-Drain Body Diode Characteristics

Symbol	Parameter	Min	Typ	Max	Unit	Test Condition
I_{SD}	Continuous Source Current ^[1]	-	-	70	A	Integral pn-diode in MOSFET
I_{SM}	Pulsed Source Current ^[1]	-	-	280		
V_{SD}	Diode Forward Voltage	-	-	1.2	V	$I_S=20A, V_{GS}=0V$
t_{rr}	Reverse Recovery Time	-	40	-	ns	$I_F=20A,$ $di_F/dt=100A/\mu s$
Q_{rr}	Reverse Recovery Charge	-	66	-	nC	

[1] Pulse width $\leq 380\mu s$; duty cycle $\leq 2\%$



Typical Characteristic

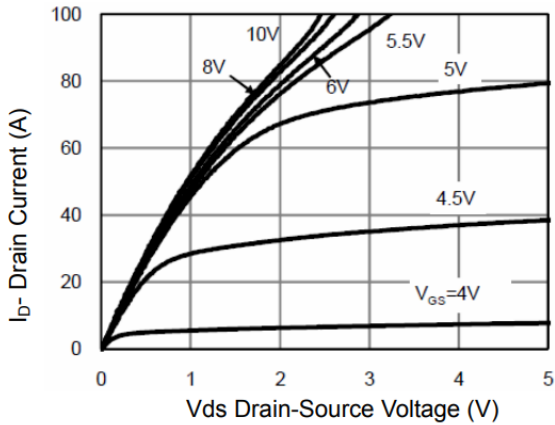

Figure 1 Output Characteristics

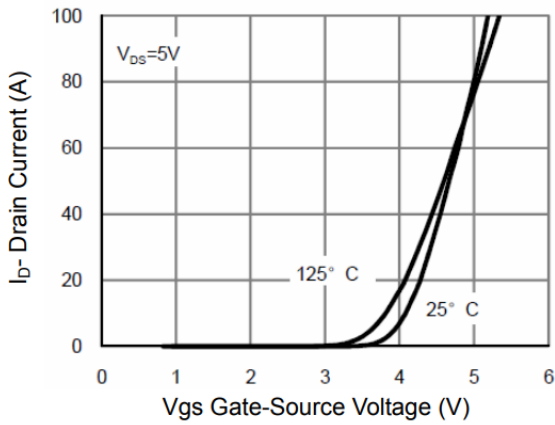

Figure 2 Transfer Characteristics

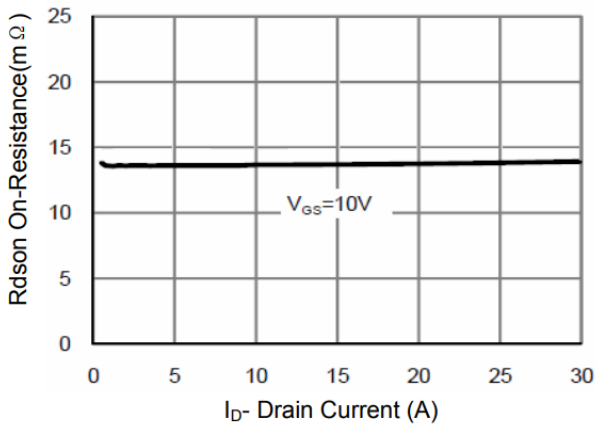

Figure 3 $R_{ds(on)}$ - Drain Current

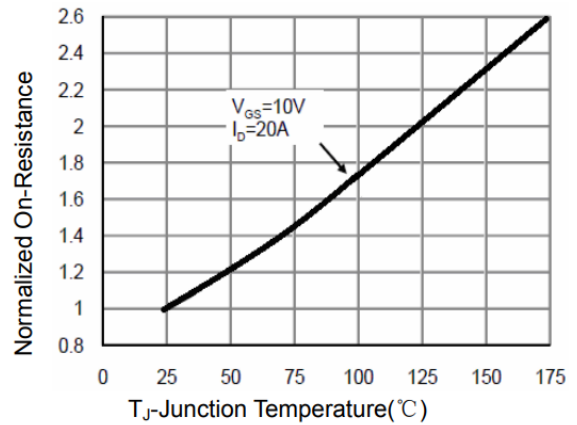

Figure 4 $R_{ds(on)}$ -Junction Temperature

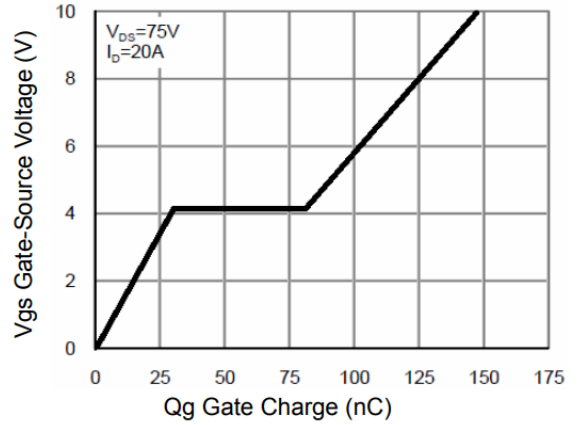

Figure 5 Gate Charge

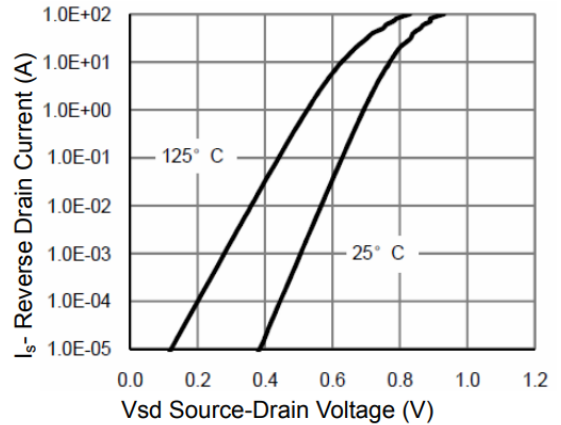

Figure 6 Source- Drain Diode Forward



Typical Characteristics(Cont.)

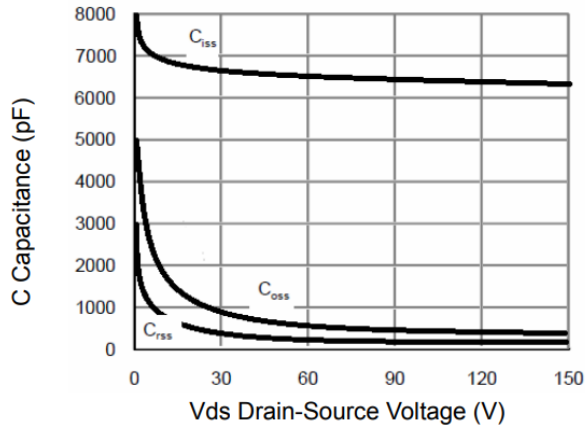

Figure 7 Capacitance vs Vds

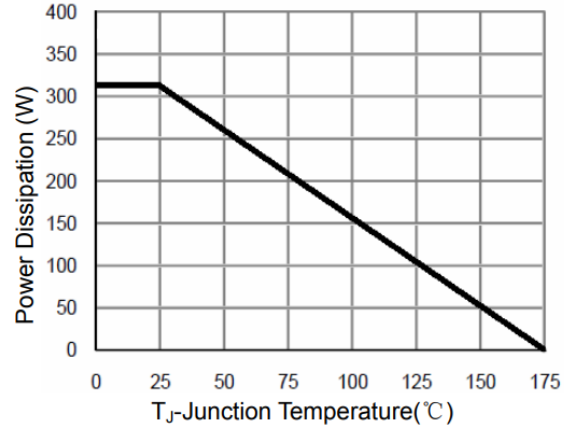

Figure 9 Power De-rating

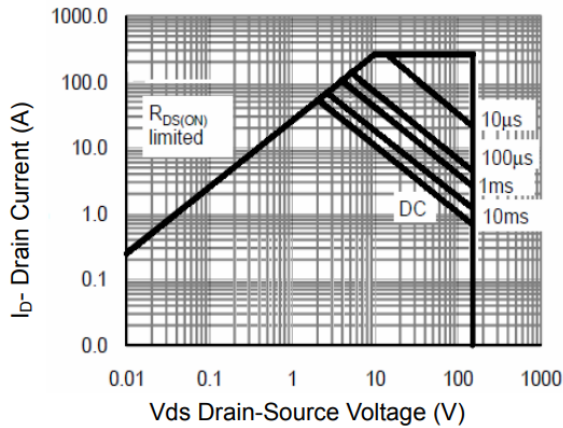

Figure 8 Safe Operation Area

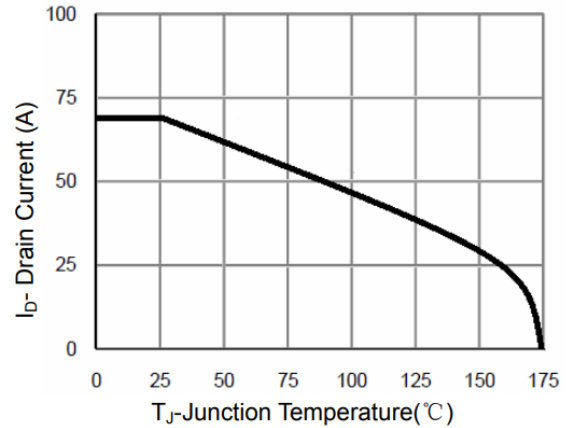

Figure 10 Current De-rating

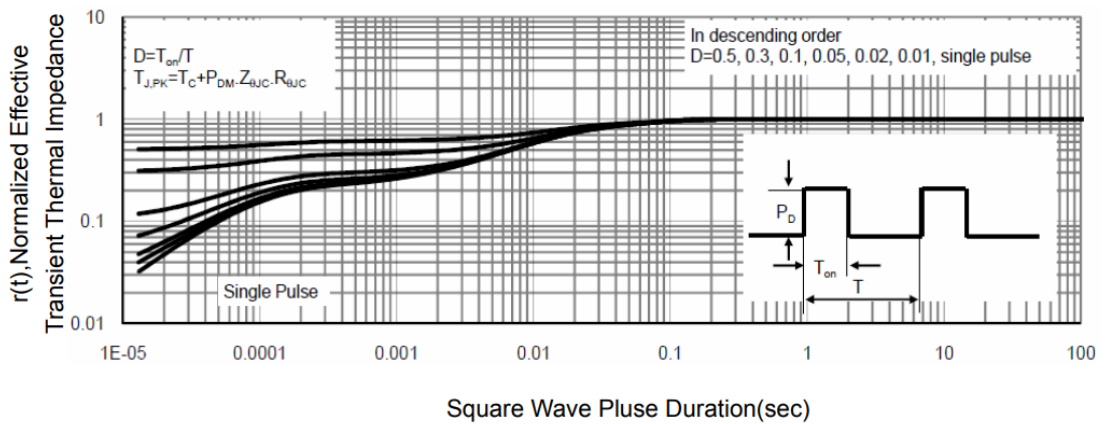

Figure 11 Normalized Maximum Transient Thermal Impedance



Test Circuits and Waveforms

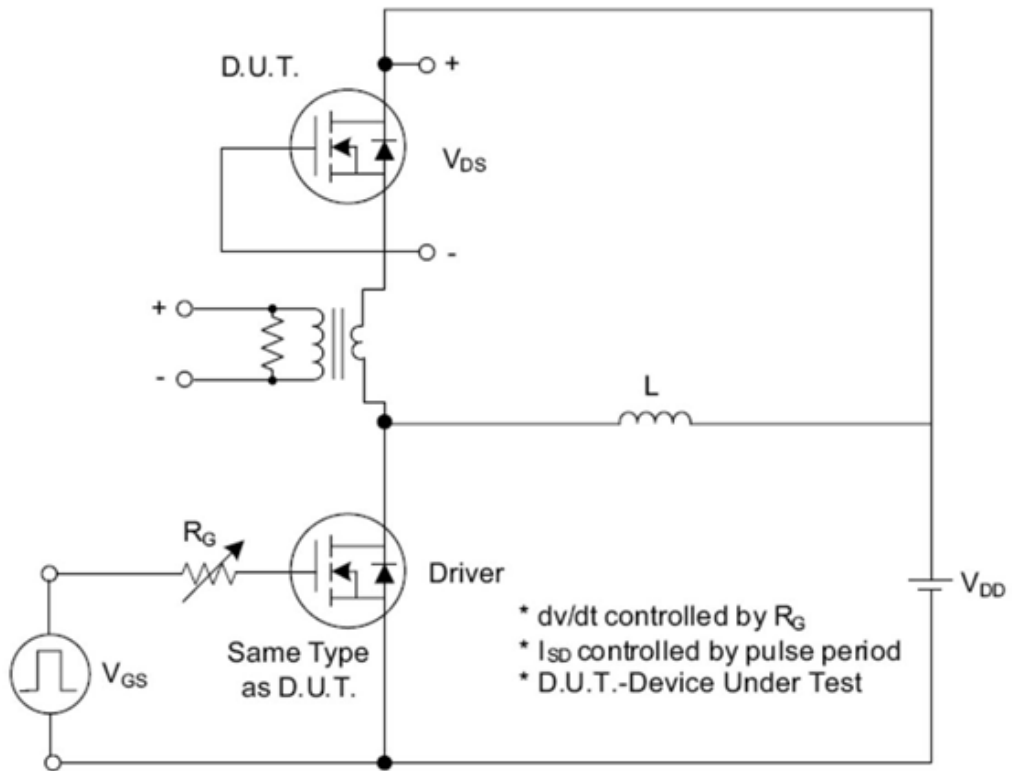

Fig. 1.1 Peak Diode Recovery dv/dt Test Circuit

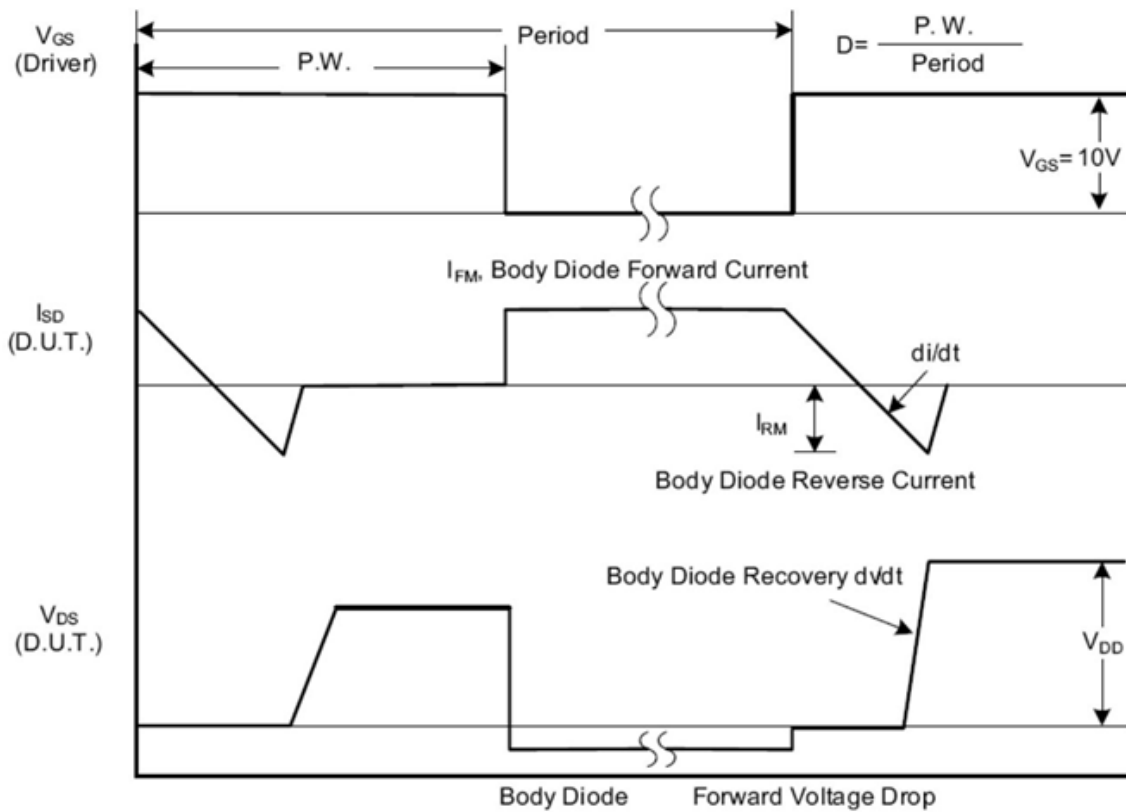

Fig. 1.2 Peak Diode Recovery dv/dt Waveforms



Test Circuits and Waveforms (Cont.)

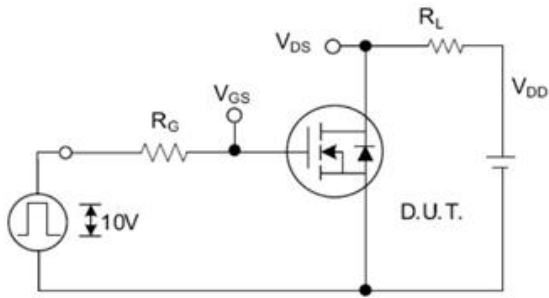

Fig. 2.1 Switching Test Circuit

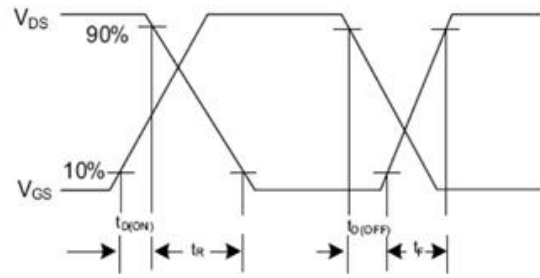

Fig. 2.2 Switching Waveforms

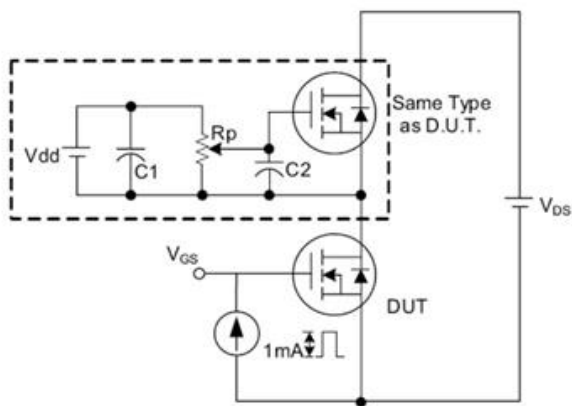

Fig. 3.1 Gate Charge Test Circuit

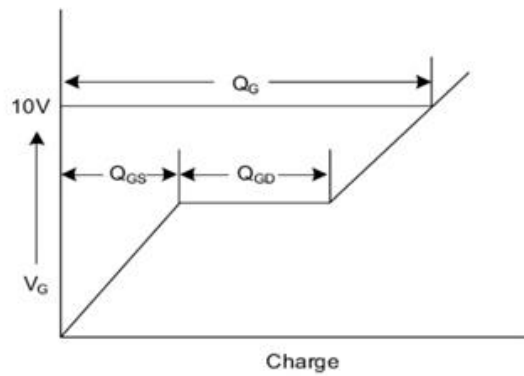

Fig. 3.2 Gate Charge Waveform

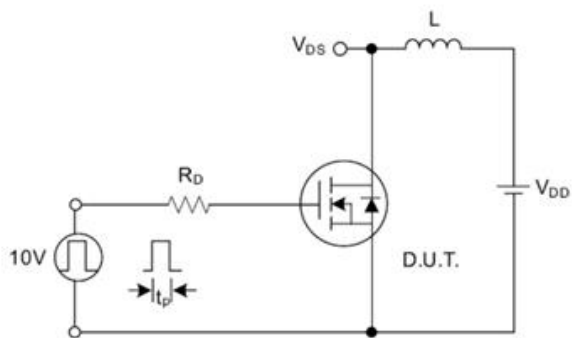

Fig. 4.1 Unclamped Inductive Switching Test Circuit

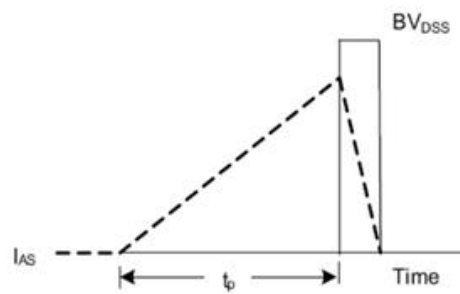

Fig. 4.2 Unclamped Inductive Switching Waveforms