



XTMT10N121D

100V N-Channel MOSFET

Product Description

BV_{DSS}	100	V
I_D	120	A
$R_{DS(ON),Typ.}$	4.6	m Ω

General Features

- Proprietary New Planar Technology
- $R_{DS(ON),typ.}=4.6\text{ m}\Omega@V_{GS}=10V$
- Fast Recovery Body Diode
- Low Gate Charge Minimize Switching Loss

Applications

- Synchronous Rectification
- UPS Inverter

封装 Package

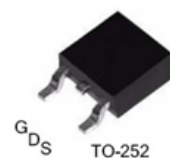
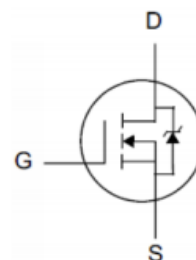

Device	Package	Marking
XTMT10N121D	TO-252	XTMT10N121D

Absolute Maximum Ratings $T_j=25^\circ\text{C}$

Symbol	Parameter	Value	Unit
V_{DSS}	Drain-to-Source Voltage	100	V
V_{GSS}	Gate-to-Source Voltage	± 20	
I_D	Continuous Drain Current	120	A
I_{DM}	Pulsed Drain Current at $V_{GS}=10V$	480	
P_D	Power Dissipation	160	W
E_{AS}	Single Pulse Avalanche Energy	400	mJ
T_L	Soldering Temperature Distance of 1.6mm from case for 10 seconds	300	$^\circ\text{C}$
$T_J \& T_{STG}$	Operating and Storage Temperature Range	-55 to 150	

Caution: Stresses greater than those listed in the "Absolute Maximum Ratings" may cause permanent damage to the device.



Thermal Characteristics

Symbol	Parameter	Value	Unit
$R_{\theta JC}$	Thermal Resistance, Junction-to-Case	0.78	$^{\circ}\text{C/W}$
$R_{\theta JA}$	Thermal Resistance, Junction-to-Ambient	62.5	$^{\circ}\text{C/W}$

Electrical Characteristics $T_j=25^{\circ}\text{C}$

OFF Characteristics

Symbol	Parameter	Min	Typ	Max	Unit	Test Condition
BV_{DSS}	Drain-to-Source Breakdown Voltage	100	-	-	V	$V_{GS}=0\text{V}, I_D=250\mu\text{A}$
I_{DSS}	Drain-to-Source Leakage Current	-	-	1	uA	$V_{DS}=100\text{V}, V_{GS}=0\text{V}$
		-	-	100		$V_{DS}=80\text{V}, V_{GS}=0\text{V}, T_J=125^{\circ}\text{C}$
I_{GSS}	Gate-to-Source Leakage Current	-	-	+100	nA	$V_{GS}=+20\text{V}, V_{DS}=0\text{V}$
		-	-	-100		$V_{GS}=-20\text{V}, V_{DS}=0\text{V}$

ON Characteristics

Symbol	Parameter	Min	Typ	Max	Unit	Test Condition
$R_{DS(ON)}$	Static Drain-to-Source On-Resistance	-	4.6	5.5	m Ω	$V_{GS}=10\text{V}, I_D=50\text{A}$
$V_{GS(TH)}$	Gate Threshold Voltage	2.0	-	4.0	V	$V_{DS}=V_{GS}, I_D=250\mu\text{A}$

**Dynamic Characteristics**

Symbol	Parameter	Min	Typ	Max	Unit	Test Condition
C_{iss}	Input Capacitance	-	3815	-	pF	$V_{GS}=0V$, $V_{DS}=25V$, $f=1.0MHz$
C_{rss}	Reverse Transfer Capacitance	-	26	-		
C_{oss}	Output Capacitance	-	652	-		
Q_g	Total Gate Charge	-	64	-	nC	$V_{DD}=40V$, $I_D=50A$, $V_{GS}=0$ to 10V
Q_{gs}	Gate-to-Source Charge	-	23	-		
Q_{gd}	Gate-to-Drain (Miller) Charge	-	17	-		

Resistive Switching Characteristics

Symbol	Parameter	Min	Typ	Max	Unit	Test Condition
$t_{d(ON)}$	Turn-on Delay Time	-	49	-	ns	$V_{DD}=40V$, $I_D=13.3A$, $V_{GS}=10V$ $R_g=24\Omega$
t_{rise}	Rise Time	-	76	-		
$t_{d(OFF)}$	Turn-Off Delay Time	-	157	-		
t_{fall}	Fall Time	-	87	-		

Source-Drain Body Diode Characteristics

Symbol	Parameter	Min	Typ	Max	Unit	Test Condition
I_{SD}	Continuous Source Current ^[1]	-	-	120	A	Integral pn-diode in MOSFET
I_{SM}	Pulsed Source Current ^[1]	-	-	480		
V_{SD}	Diode Forward Voltage	-	-	1.4	V	$I_S=50A$, $V_{GS}=0V$
t_{rr}	Reverse Recovery Time	-	66	-	ns	$I_F=20A$, $di_F/dt=100A/\mu s$
Q_{rr}	Reverse Recovery Charge	-	0.15	-	uC	

[1] Pulse width $\leq 380\mu s$; duty cycle $\leq 2\%$



Typical Characteristics

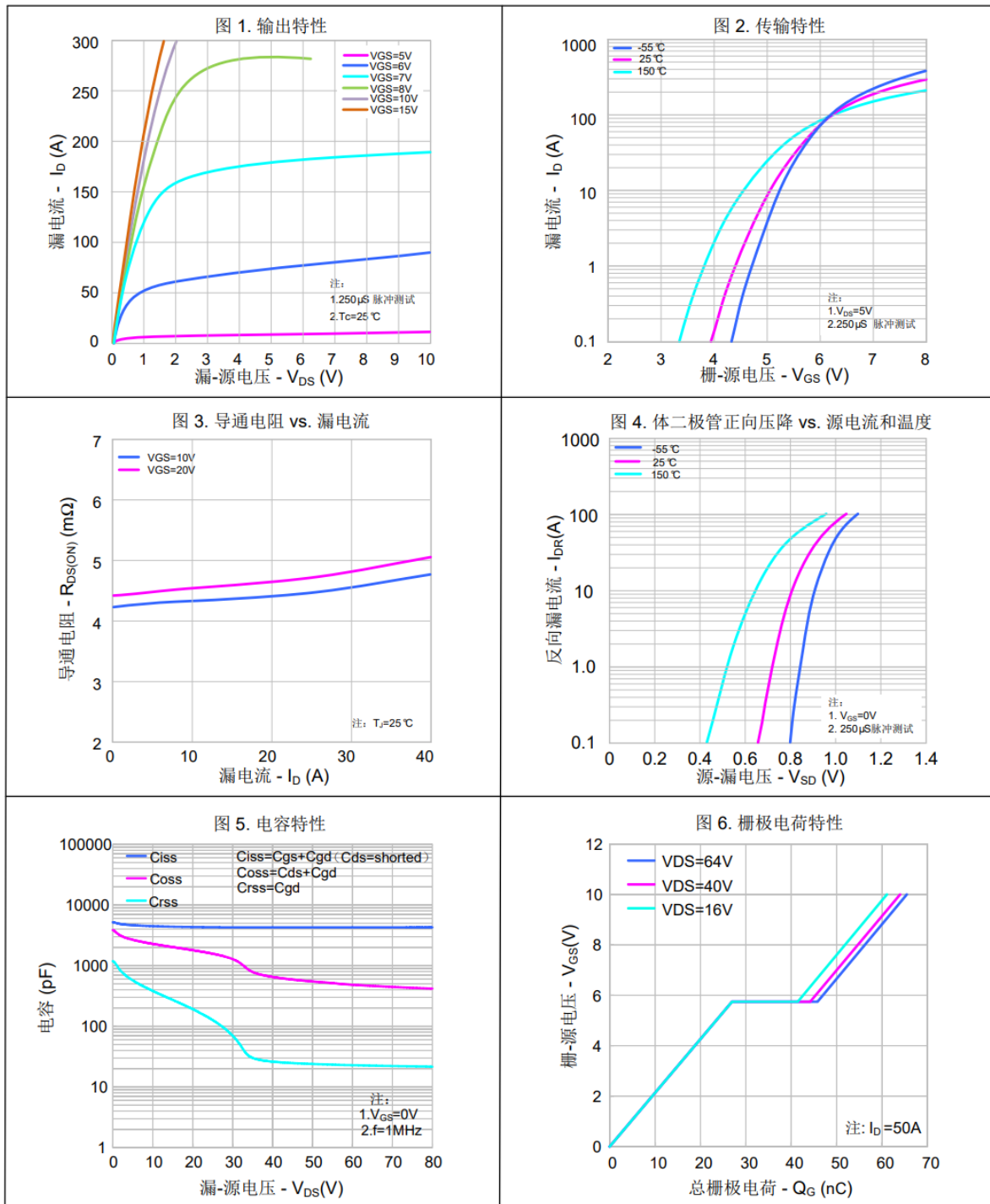



Typical Characteristics

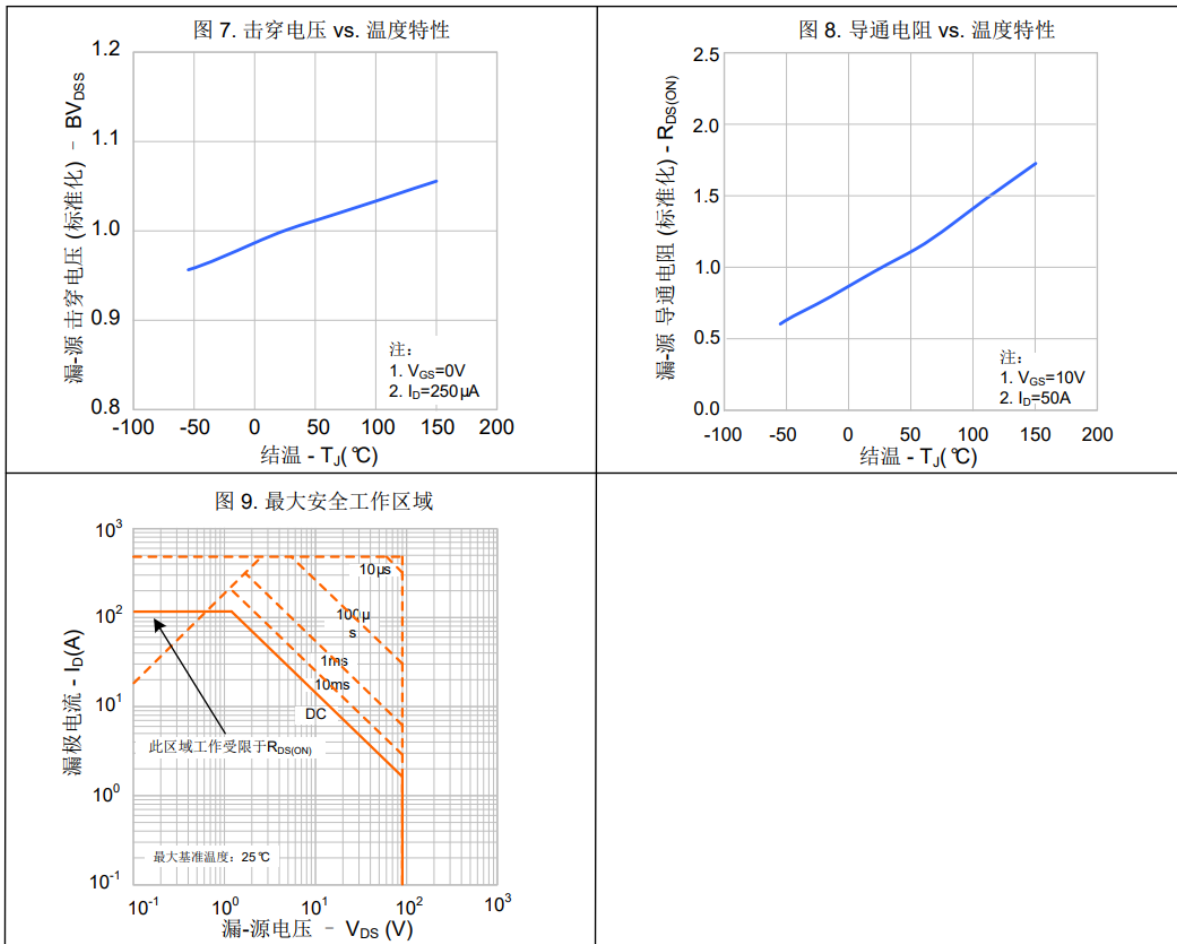



Test Circuits and Waveforms

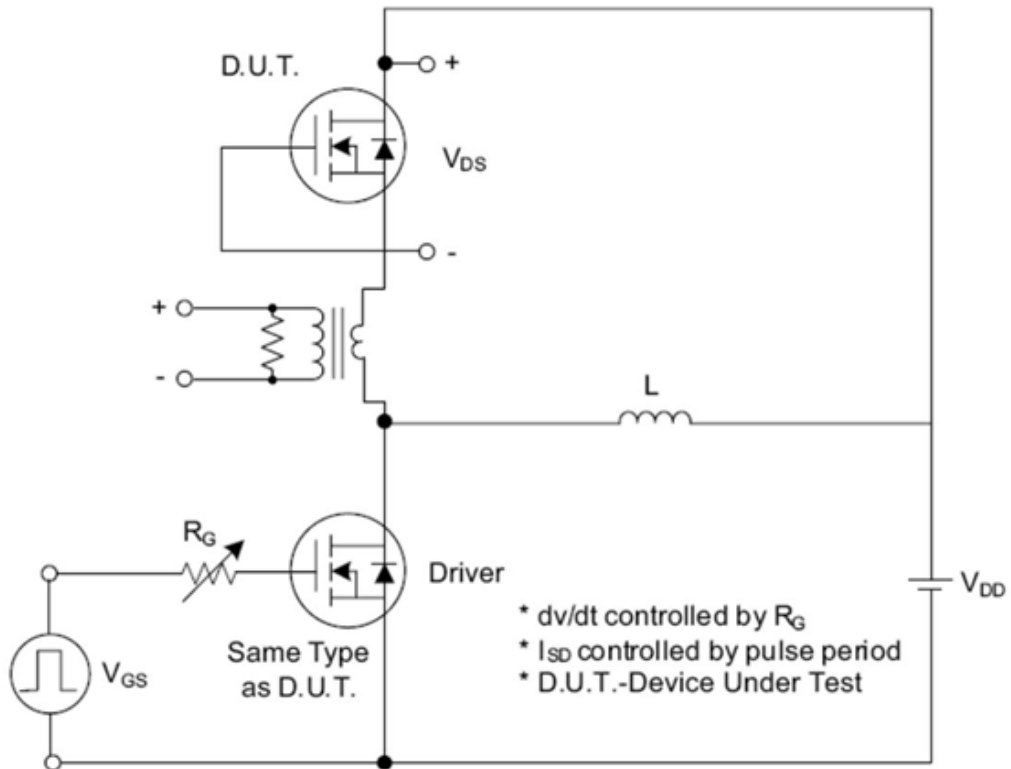

Fig. 1.1 Peak Diode Recovery dv/dt Test Circuit

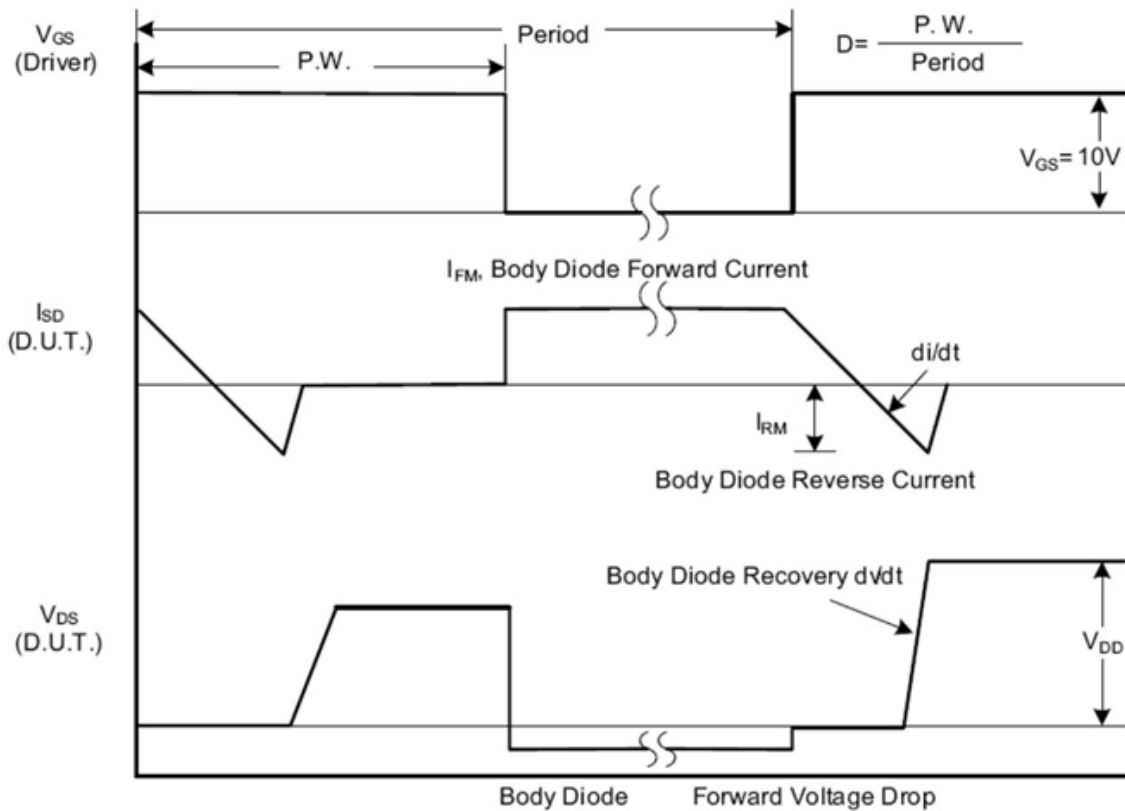

Fig. 1.2 Peak Diode Recovery dv/dt Waveforms



Test Circuits and Waveforms (Cont.)

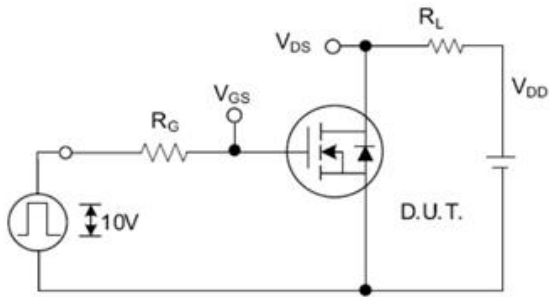

Fig. 2.1 Switching Test Circuit

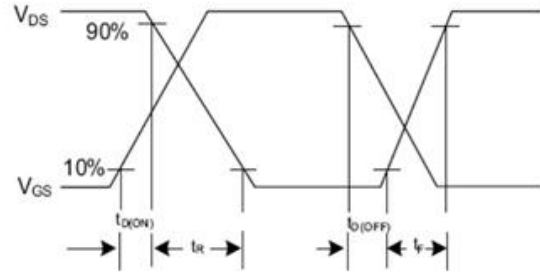

Fig. 2.2 Switching Waveforms

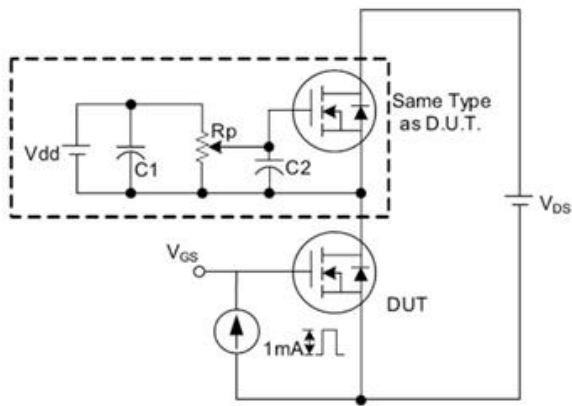

Fig. 3.1 Gate Charge Test Circuit

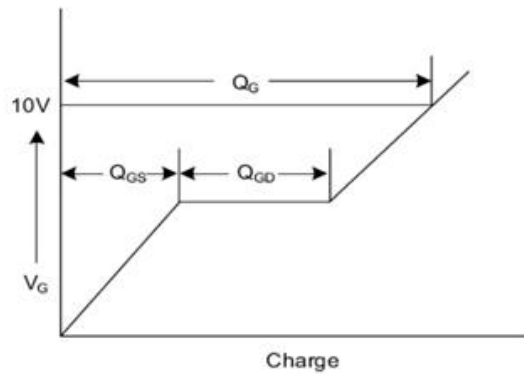

Fig. 3.2 Gate Charge Waveform

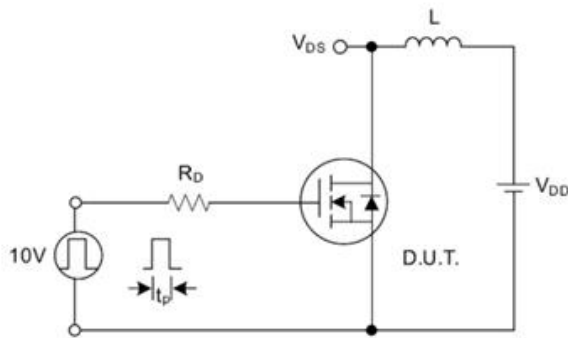

Fig. 4.1 Unclamped Inductive Switching Test Circuit

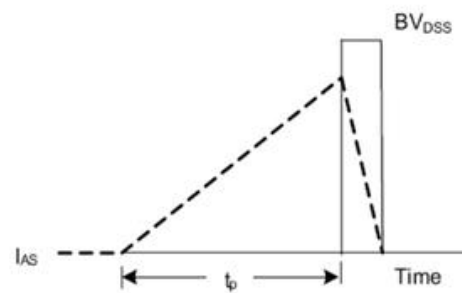

Fig. 4.2 Unclamped Inductive Switching Waveforms