



# XTMT03N90D

## 30V N-Channel MOSFET

### Product Description

$BV_{DSS}$	30	V
$I_D$	90	A
$R_{DS(ON),Typ.}$	3.0	m $\Omega$

### General Features

- Proprietary New Planar Technology
- $R_{DS(ON),typ.}=3.0\text{ m}\Omega@V_{GS}=10V$
- Fast Recovery Body Diode
- Low Gate Charge Minimize Switching Loss

### Applications

- Uninterruptible Power Supply
- Power Switching application

### 封装 Package

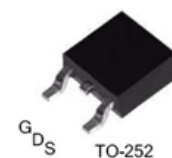
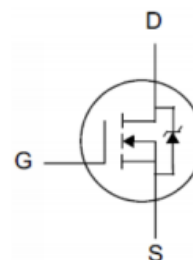

Device	Package	Marking
XTMT03N90D	TO-252	XTMT03N90D

### Absolute Maximum Ratings $T_j=25^\circ\text{C}$

Symbol	Parameter	Value	Unit
$V_{DSS}$	Drain-to-Source Voltage	30	V
$V_{GSS}$	Gate-to-Source Voltage	$\pm 20$	
$I_D$	Continuous Drain Current	90	A
$I_{DM}$	Pulsed Drain Current at $V_{GS}=10V$	330	
$E_{AS}$	Single Pulse Avalanche Energy	120	mJ
$P_D$	Power Dissipation	65	W
$T_L$	Soldering Temperature Distance of 1.6mm from case for 10 seconds	300	$^\circ\text{C}$
$T_J \& T_{STG}$	Operating and Storage Temperature Range	-55 to 150	

Caution: Stresses greater than those listed in the "Absolute Maximum Ratings" may cause permanent damage to the device.



## Thermal Characteristics

Symbol	Parameter	Value	Unit
$R_{\theta JC}$	Thermal Resistance, Junction-to-Case	1.92	$^{\circ}C/W$
$R_{\theta JA}$	Thermal Resistance, Junction-to-Ambient	50	$^{\circ}C/W$

## Electrical Characteristics $T_j=25^{\circ}C$

### OFF Characteristics

Symbol	Parameter	Min	Typ	Max	Unit	Test Condition
$BV_{DSS}$	Drain-to-Source Breakdown Voltage	30	-	-	V	$V_{GS}=0V, I_D=250\mu A$
$I_{DSS}$	Drain-to-Source Leakage Current	-	-	1	uA	$V_{DS}=30V, V_{GS}=0V$
		-	-	100		$V_{DS}=24V, V_{GS}=0V, T_J=125^{\circ}C$
$I_{GSS}$	Gate-to-Source Leakage Current	-	-	+100	nA	$V_{GS}=+20V, V_{DS}=0V$
		-	-	-100		$V_{GS}=-20V, V_{DS}=0V$

### ON Characteristics

Symbol	Parameter	Min	Typ	Max	Unit	Test Condition
$R_{DS(ON)}$	Static Drain-to-Source On-Resistance	-	3.0	4.0	m $\Omega$	$V_{GS}=10V, I_D=20A$
		-	5.4	6.8	m $\Omega$	$V_{GS}=4.5V, I_D=16A$
$V_{GS(TH)}$	Gate Threshold Voltage	1.2	-	2.2	V	$V_{DS}=V_{GS}, I_D=250\mu A$



## Dynamic Characteristics

Symbol	Parameter	Min	Typ	Max	Unit	Test Condition
$C_{iss}$	Input Capacitance	-	2337	-	pF	$V_{GS}=0V$ , $V_{DS}=15V$ , $f=1.0MHz$
$C_{rss}$	Reverse Transfer Capacitance	-	316	-		
$C_{oss}$	Output Capacitance	-	360	-		
$R_G$	Gate Series Resistance		2.8		$\Omega$	$f=1.0MHz$
$Q_g$	Total Gate Charge	-	23	-	nC	$V_{DD}=15V$ , $I_D=20A$ , $V_{GS}=4.5V$
$Q_{gs}$	Gate-to-Source Charge	-	9.0	-		
$Q_{gd}$	Gate-to-Drain (Miller) Charge	-	10	-		

## Resistive Switching Characteristics

Symbol	Parameter	Min	Typ	Max	Unit	Test Condition
$t_{d(ON)}$	Turn-on Delay Time	-	12	-	ns	$V_{DD}=20V$ , $I_D=20A$ , $V_{GS}=10V$ $R_g=6\Omega$
$t_{rise}$	Rise Time	-	72	-		
$t_{d(OFF)}$	Turn-Off Delay Time	-	63	-		
$t_{fall}$	Fall Time	-	104	-		

## Source-Drain Body Diode Characteristics

Symbol	Parameter	Min	Typ	Max	Unit	Test Condition
$I_{SD}$	Continuous Source Current <sup>[1]</sup>	-	-	90	A	Integral pn-diode in MOSFET
$I_{SM}$	Pulsed Source Current <sup>[1]</sup>	-	-	330		
$V_{SD}$	Diode Forward Voltage	-	-	1.4	V	$I_S=2.5A$ , $V_{GS}=0V$
$t_{rr}$	Reverse Recovery Time	-	20	-	ns	$I_F=20A$ , $di_F/dt=100A/\mu s$
$Q_{rr}$	Reverse Recovery Charge	-	10	-	nC	

[1] Pulse width $\leq 380\mu s$ ; duty cycle $\leq 2\%$



### Typical Characteristic

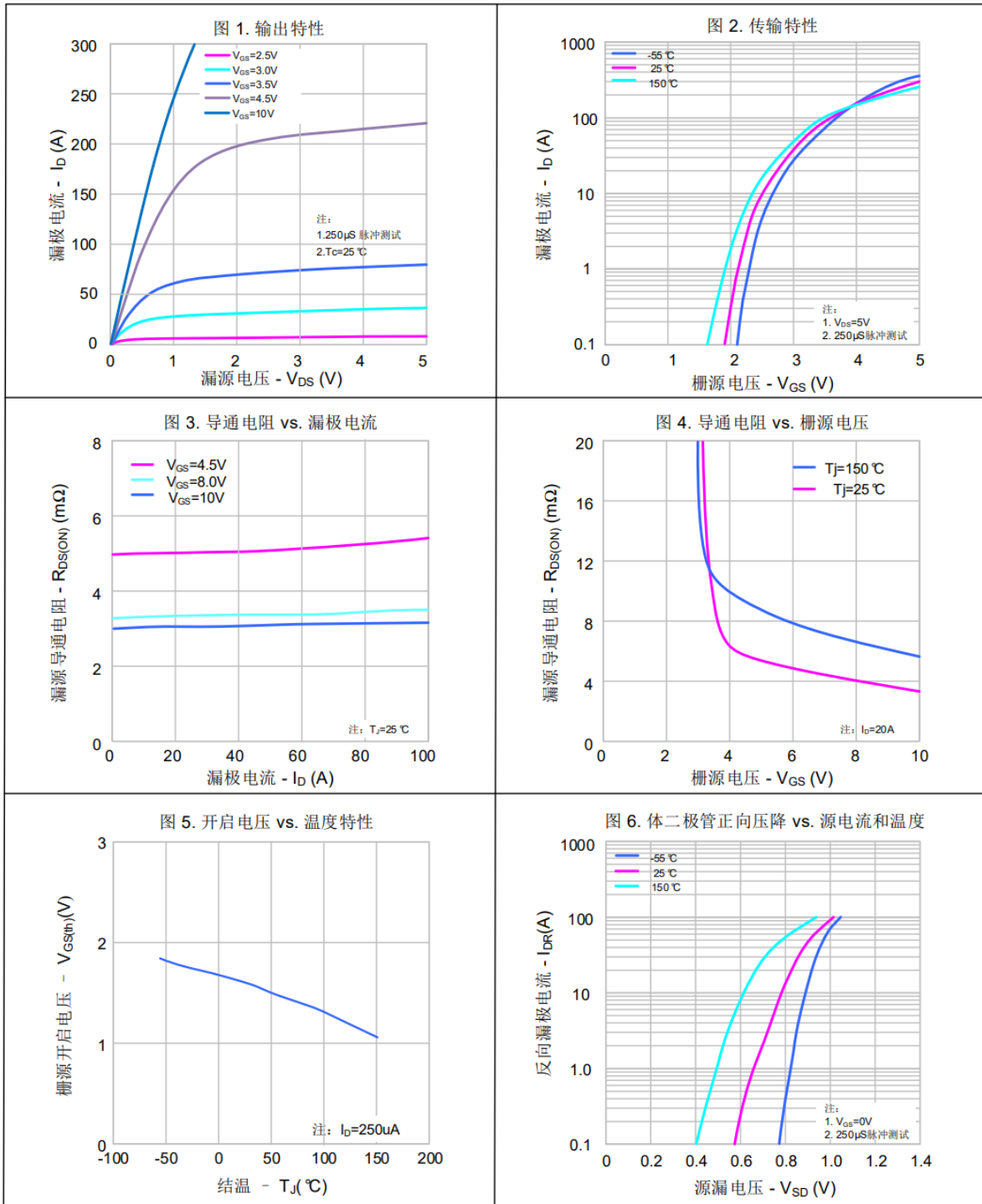



### Typical Characteristics(Cont.)

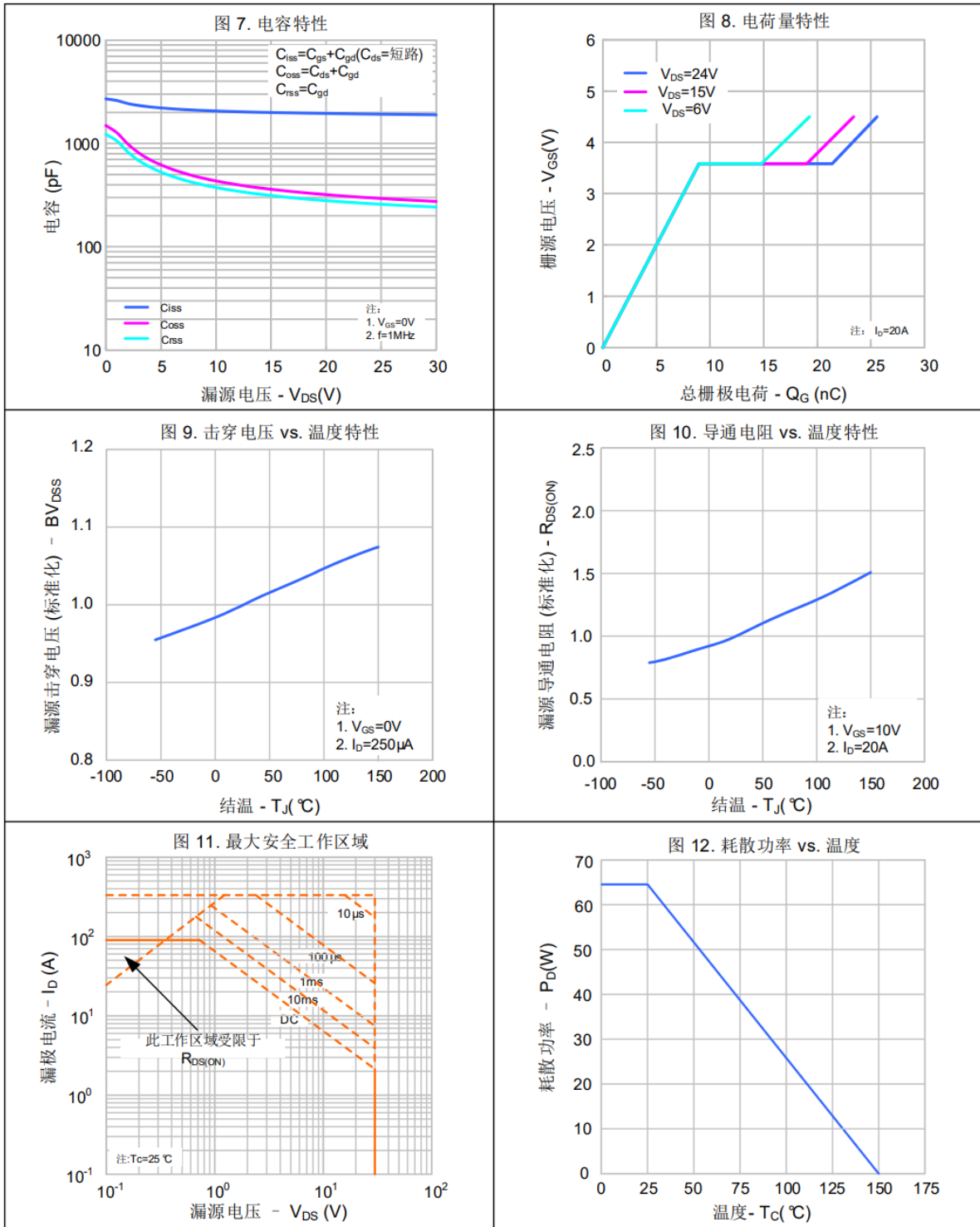



Test Circuits and Waveforms

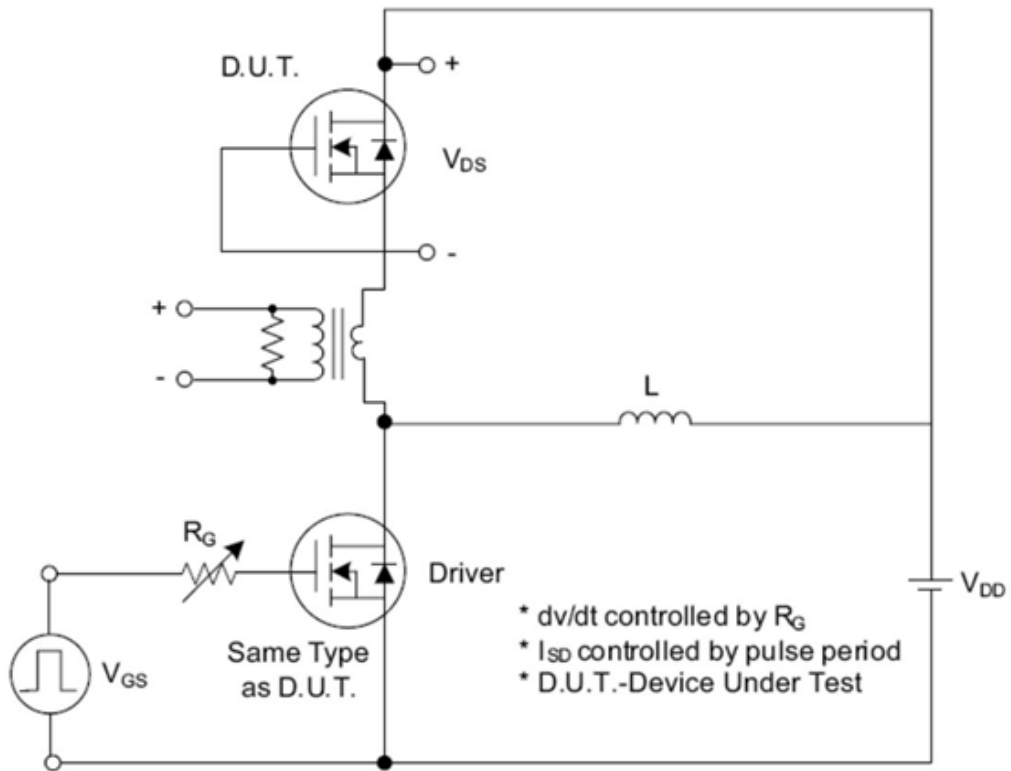

Fig. 1.1 Peak Diode Recovery  $dv/dt$  Test Circuit

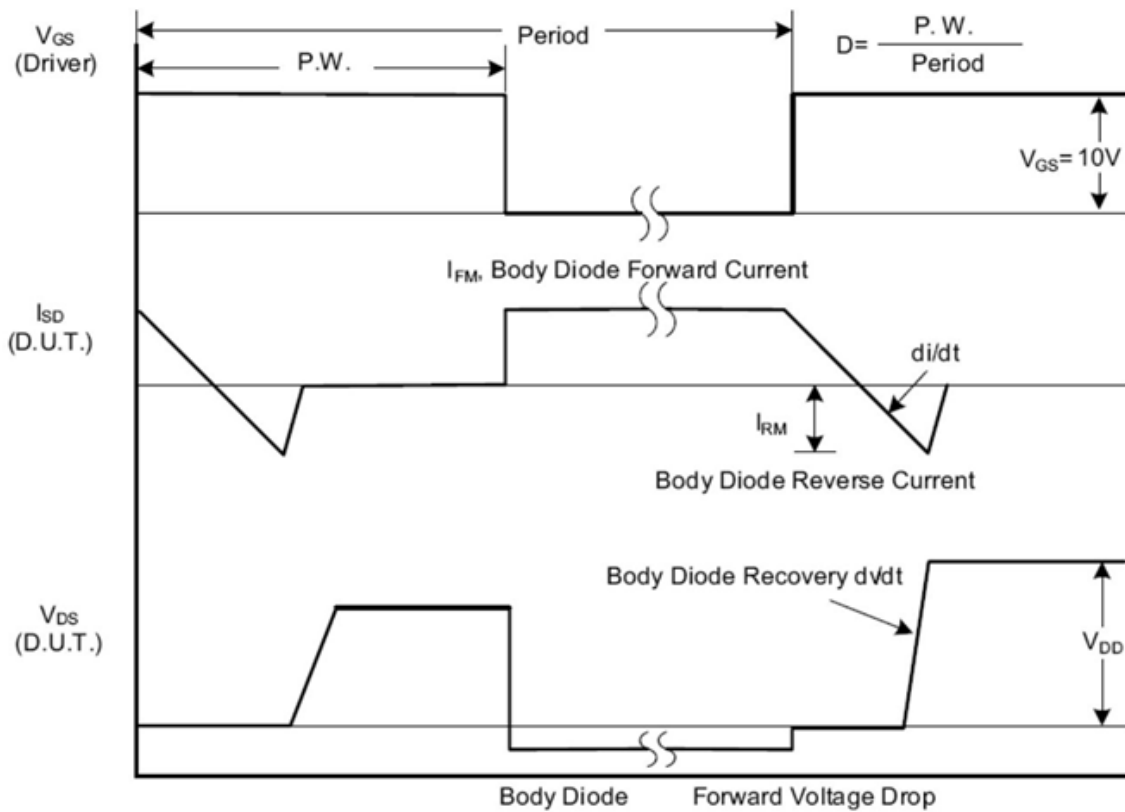

Fig. 1.2 Peak Diode Recovery  $dv/dt$  Waveforms



Test Circuits and Waveforms (Cont.)

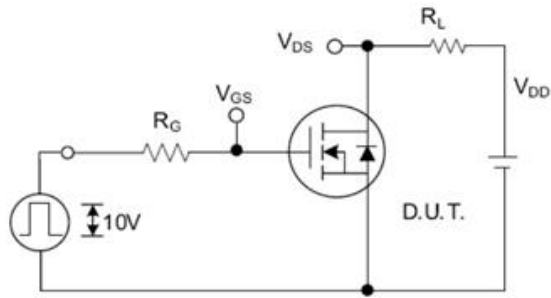

Fig. 2.1 Switching Test Circuit

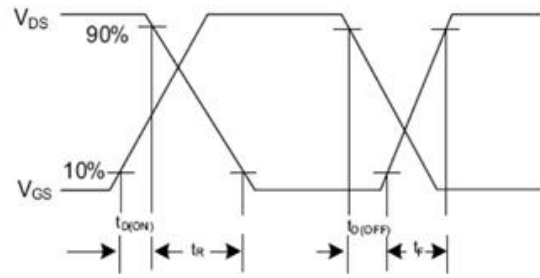

Fig. 2.2 Switching Waveforms

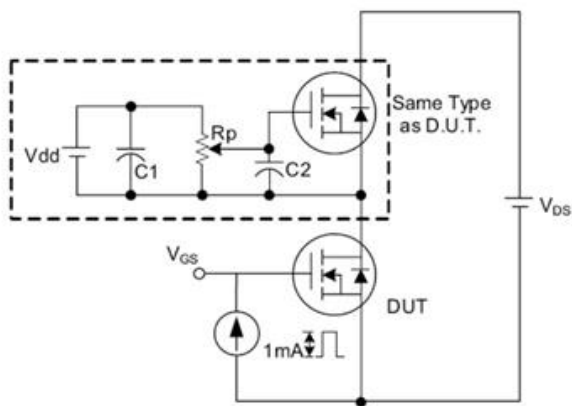

Fig. 3.1 Gate Charge Test Circuit

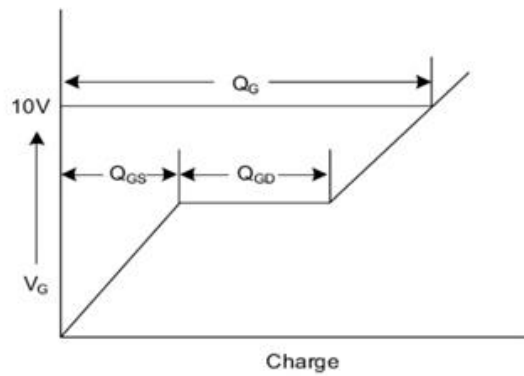

Fig. 3.2 Gate Charge Waveform

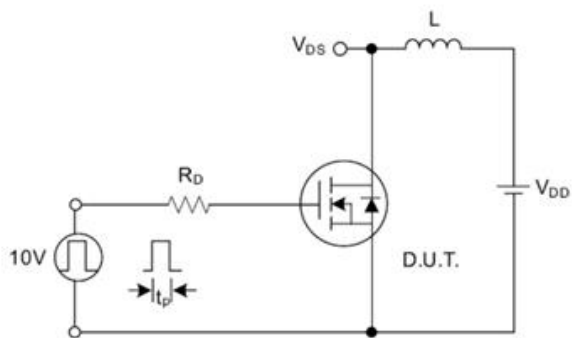

Fig. 4.1 Unclamped Inductive Switching Test Circuit

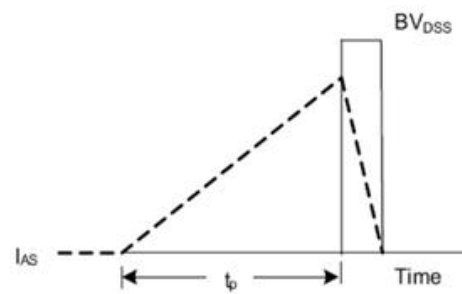

Fig. 4.2 Unclamped Inductive Switching Waveforms