



XTMF90N09E

900V N-ch Planar MOSFET

Product Description

BV_{DSS}	900	V
I_D	9	A
$R_{DS(ON), Typ.}$	0.98	Ω

General Features

- Proprietary New Planar Technology
- $R_{DS(ON), typ.} = 0.98\Omega @ V_{GS} = 10V$
- Fast Recovery Body Diode
- Low Gate Charge Minimize Switching Loss

Applications

- Adaptor Charger
- SMPS Power Supply
- LCD Panel Power

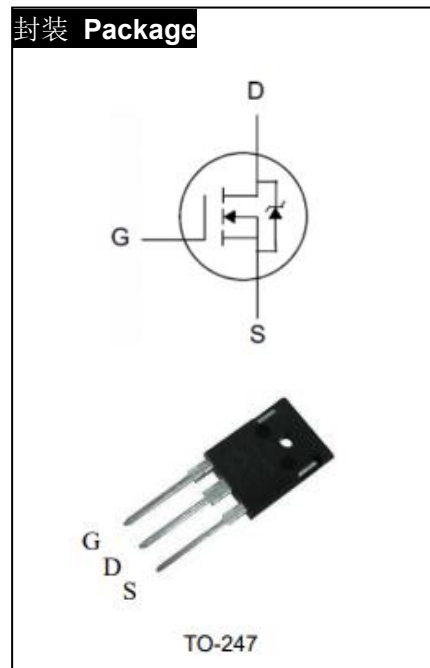

Device	Package	Marking
XTMF90N09E	TO-247	XTMF90N09E

Absolute Maximum Ratings $T_j = 25^\circ\text{C}$

Symbol	Parameter	Value	Unit
V_{DSS}	Drain-to-Source Voltage	900	V
V_{GSS}	Gate-to-Source Voltage	± 30	
I_D	Continuous Drain Current	9	A
I_{DM}	Pulsed Drain Current at $V_{GS} = 10V$	36	
E_{AS}	Single Pulse Avalanche Energy	580	mJ
P_D	Power Dissipation	75	W
	Derating Factor above 25°C	0.6	W/ $^\circ\text{C}$
T_L	Soldering Temperature Distance of 1.6mm from case for 10 seconds	300	$^\circ\text{C}$
$T_J \& T_{STG}$	Operating and Storage Temperature Range	-55 to 150	



Caution: Stresses greater than those listed in the “Absolute Maximum Ratings” may cause permanent damage to the device.

Thermal Characteristics

Symbol	Parameter	Value	Unit
$R_{\theta JC}$	Thermal Resistance, Junction-to-Case	1.67	$^{\circ}\text{C/W}$
$R_{\theta JA}$	Thermal Resistance, Junction-to-Ambient	100	$^{\circ}\text{C/W}$

Electrical Characteristics $T_j=25^{\circ}\text{C}$

OFF Characteristics

Symbol	Parameter	Min	Typ	Max	Unit	Test Condition
BV_{DSS}	Drain-to-Source Breakdown Voltage	900	-	-	V	$V_{GS}=0V, I_D=250\mu\text{A}$
I_{DSS}	Drain-to-Source Leakage Current	-	-	1	uA	$V_{DS}=900V, V_{GS}=0V$
		-	-	100		$V_{DS}=720V,$ $V_{GS}=0V, T_j=125^{\circ}\text{C}$
I_{GSS}	Gate-to-Source Leakage Current	-	-	+100	nA	$V_{GS}=+30V, V_{DS}=0V$
		-	-	-100		$V_{GS}=-30V, V_{DS}=0V$

ON Characteristics

Symbol	Parameter	Min	Typ	Max	Unit	Test Condition
$R_{DS(ON)}$	Static Drain-to-Source On-Resistance ^[4]	--	0.98	1.25	Ω	$V_{GS}=10V, I_D=4.5A$
$V_{GS(TH)}$	Gate Threshold Voltage	2.0	--	4.0	V	$V_{DS}=V_{GS},$ $I_D=250\mu\text{A}$
gfs	Forward Transconductance ^[4]	--	9.2	--	S	$V_{DS}=30V, I_D=9A$

**Dynamic Characteristics**

Symbol	Parameter	Min	Typ	Max	Unit	Test Condition
C_{iss}	Input Capacitance	--	2593	--	pF	$V_{GS}=0V$, $V_{DS}=25V, f=1.0MHz$
C_{rss}	Reverse Transfer Capacitance	--	12	--		
C_{oss}	Output Capacitance	--	146	--		
Q_g	Total Gate Charge	--	49	--	nC	$V_{DD}=450V, I_D=9A, V_{GS}=0$ to 10V
Q_{gs}	Gate-to-Source Charge	--	13	--		
Q_{gd}	Gate-to-Drain (Miller) Charge	--	17	--		

Resistive Switching Characteristics

Symbol	Parameter	Min	Typ	Max	Unit	Test Condition
$t_{d(ON)}$	Turn-on Delay Time	--	35	--	ns	$V_{DD}=450V, I_D=9A$, $V_{GS}=10V, R_G=25\Omega$
t_{rise}	Rise Time	--	41	--		
$t_{d(OFF)}$	Turn-Off Delay Time	--	134	--		
t_{fall}	Fall Time	--	45	--		

Source-Drain Body Diode Characteristics

Symbol	Parameter	Min	Typ	Max	Unit	Test Condition
I_{SD}	Continuous Source Current	--	--	9	A	Integral pn-diode in MOSFET
I_{SM}	Pulsed Source Current	--	--	36		
V_{SD}	Diode Forward Voltage	--	--	1.5	V	$I_S=9A$, $V_{GS}=0V$
t_{rr}	Reverse recovery time	--	562	--	ns	$V_{GS}=0V, I_F=9A$, $di_F/dt=100A/\mu s$
Q_{rr}	Reverse recovery charge	--	3.5	--	μC	

[1] Pulse width $\leq 380\mu s$; duty cycle $\leq 2\%$



Typical Characteristics

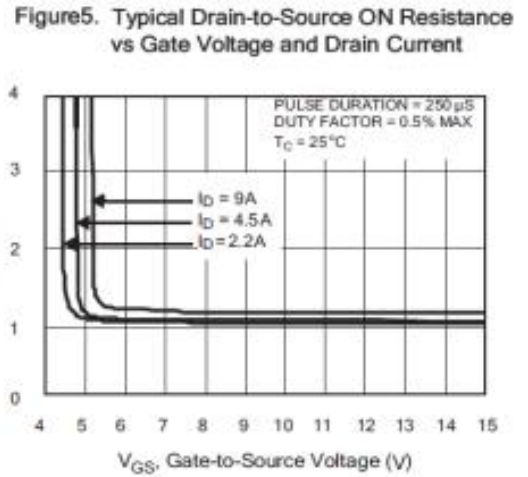
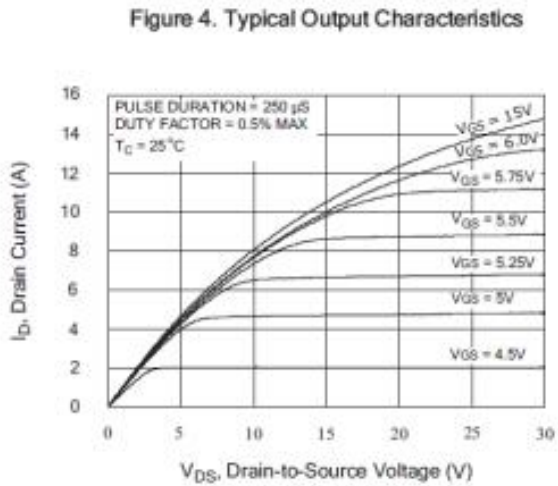
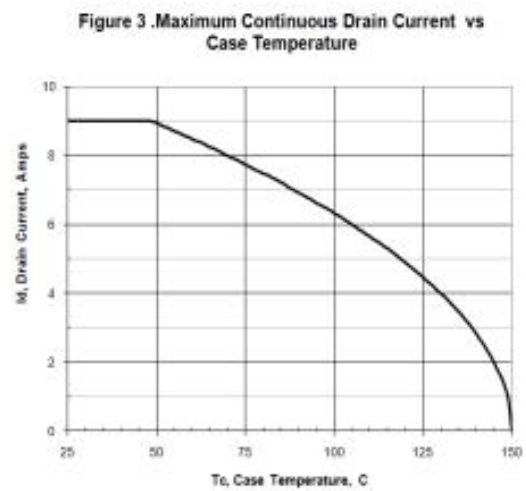
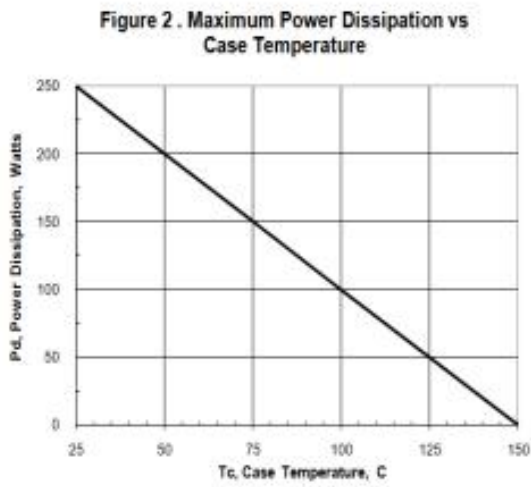
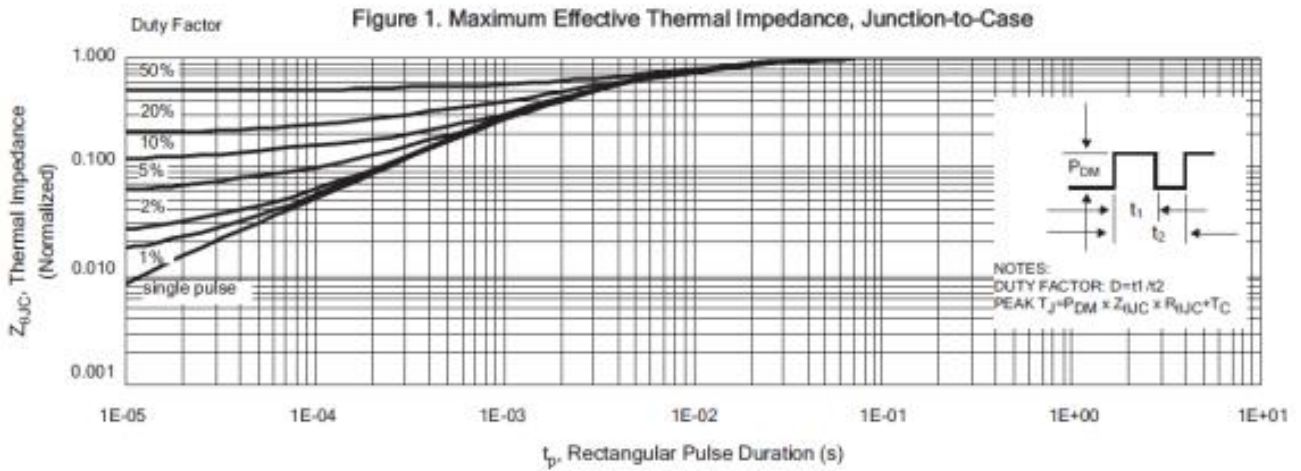



Typical Characteristics(Cont.)

Figure 6. Maximum Peak Current Capability

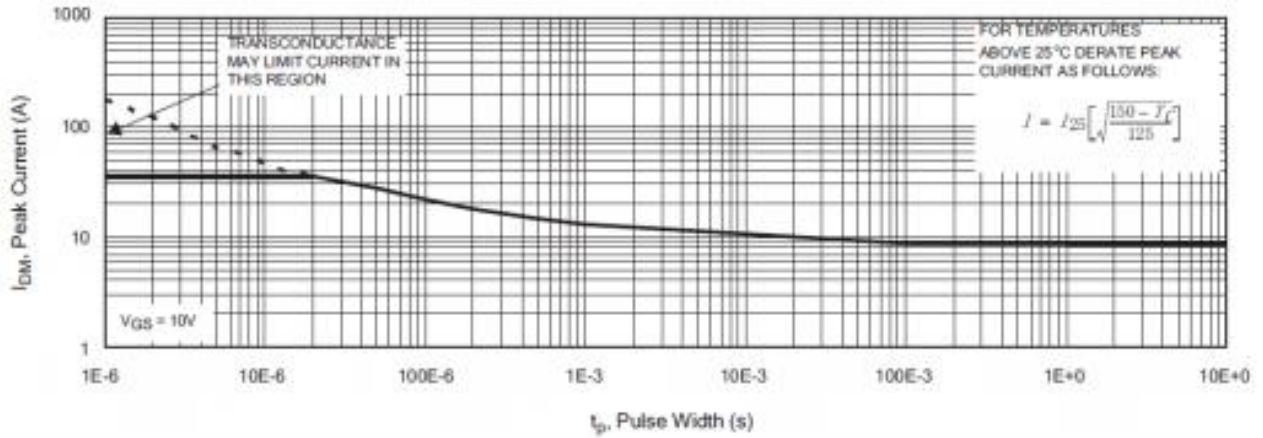

Figure 7. Typical Transfer Characteristics

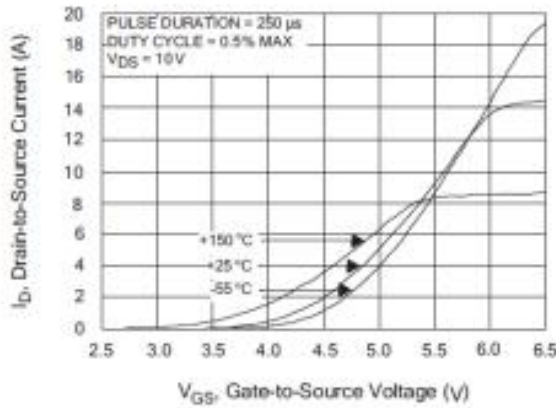

Figure 9. Typical Drain-to-Source ON Resistance vs Drain Current

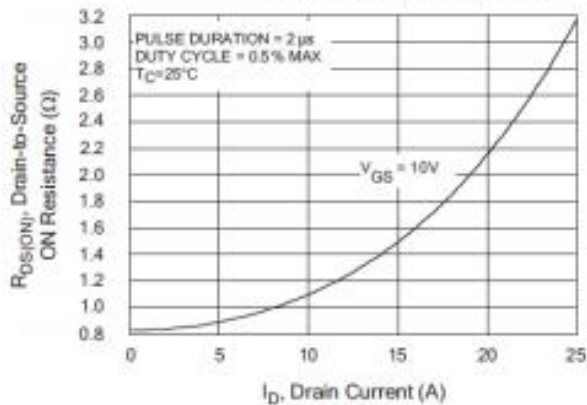

Figure 8. Unclamped Inductive Switching Capability

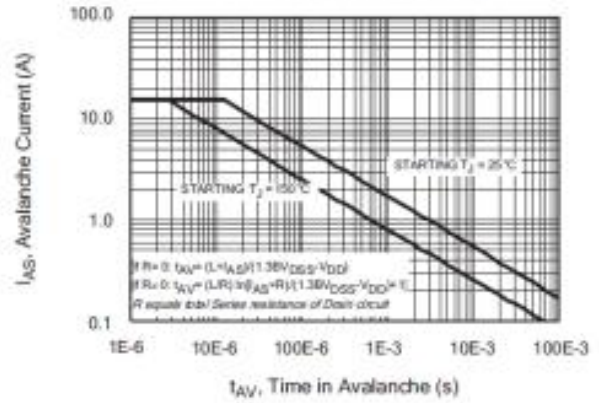
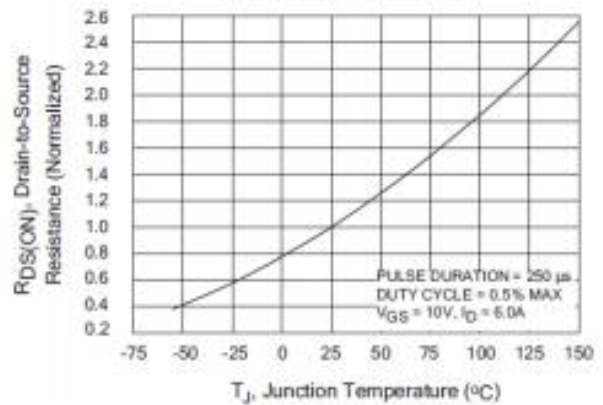

Figure 10. Typical Drain-to-Source ON Resistance vs Junction Temperature





Typical Characteristics(Cont.)

Figure 11. Typical Breakdown Voltage vs Junction Temperature

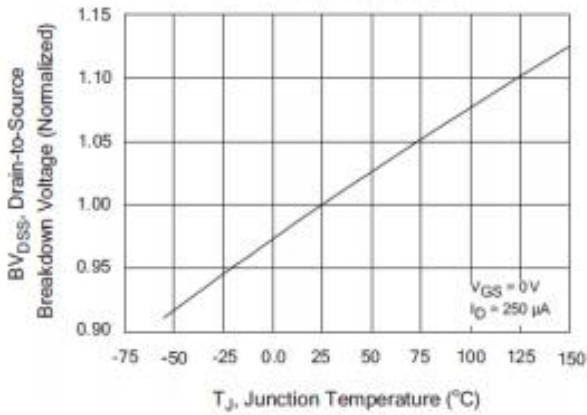

Figure 12. Typical Threshold Voltage vs Junction Temperature

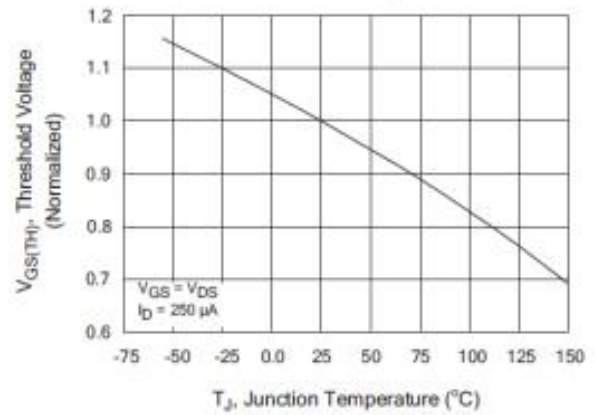

Figure 13. Maximum Forward Bias Safe Operating Area

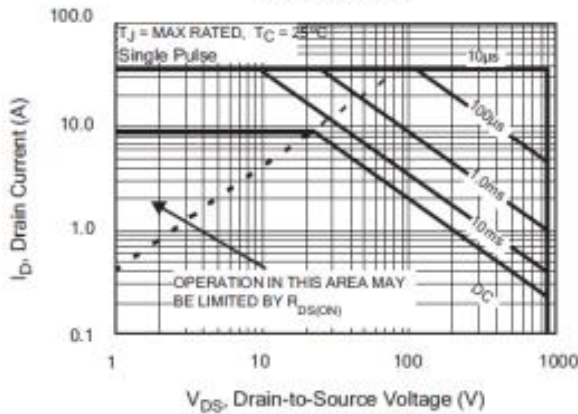

Figure 14. Capacitance vs Vds

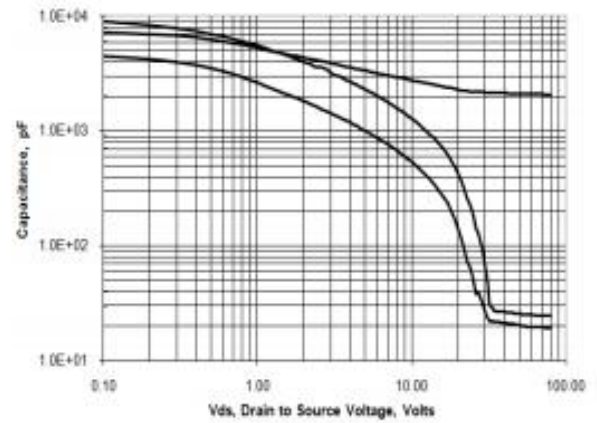

Figure 15. Typical Gate Charge

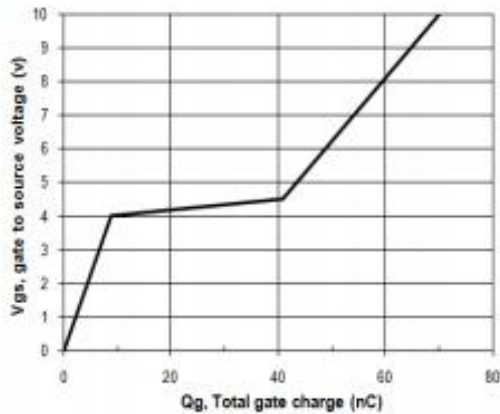
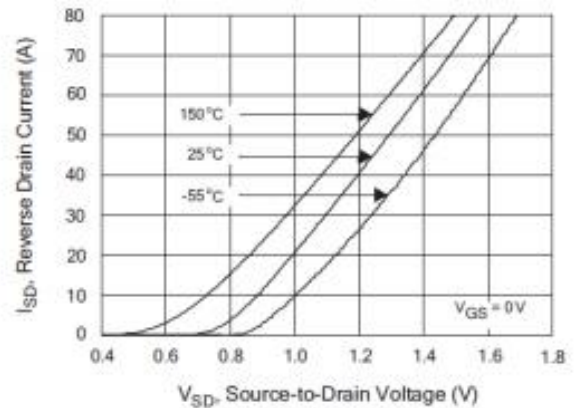

Figure 16. Typical Body Diode Transfer Characteristics





Test Circuits and Waveforms

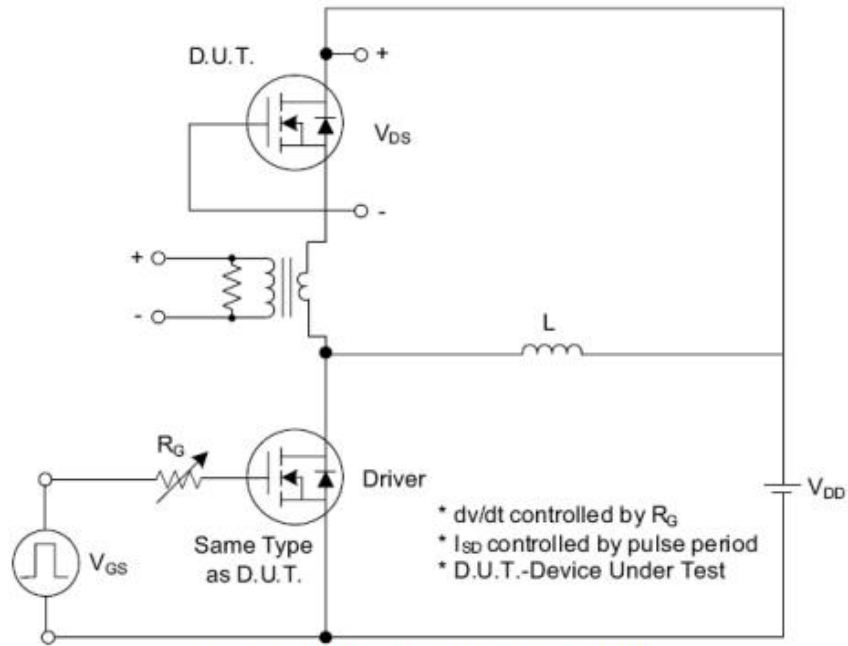

Fig. 1.1 Peak Diode Recovery dv/dt Test Circuit

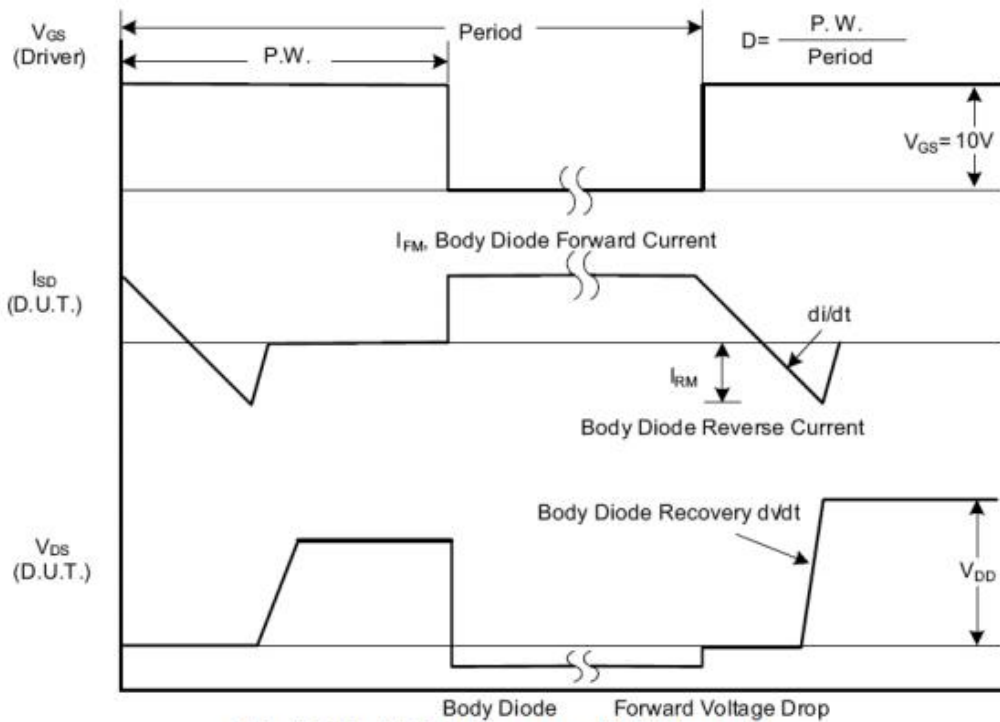

Fig. 1.2 Peak Diode Recovery dv/dt Waveforms



Test Circuits and Waveforms (cont.)

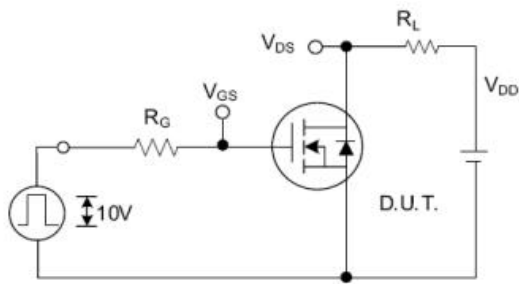

Fig. 2.1 Switching Test Circuit

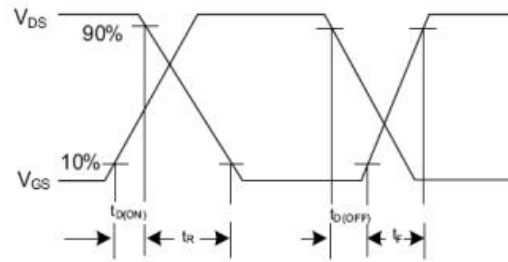

Fig. 2.2 Switching Waveforms

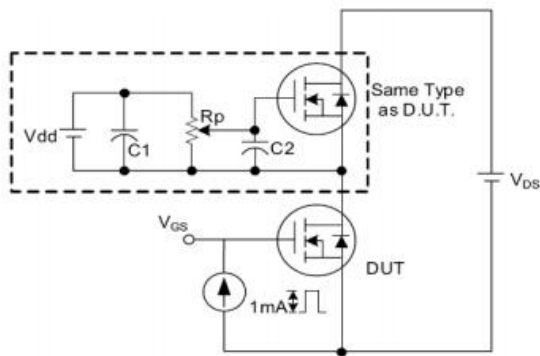

Fig. 3.1 Gate Charge Test Circuit

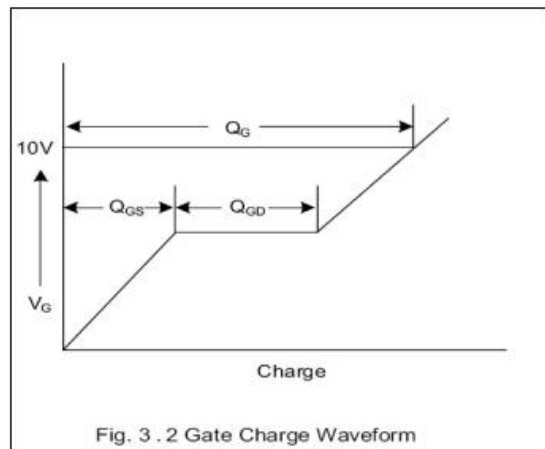

Fig. 3.2 Gate Charge Waveform

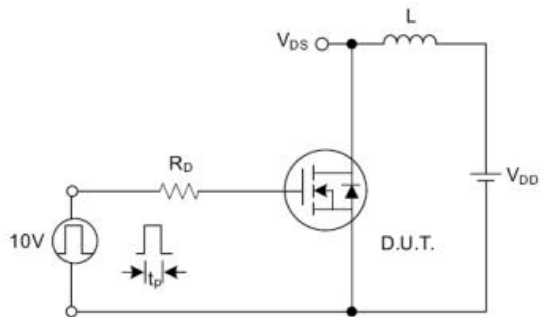

Fig. 4.1 Unclamped Inductive Switching Test Circuit

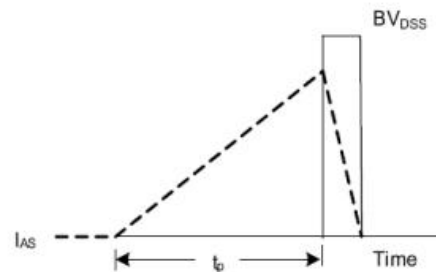

Fig. 4.2 Unclamped Inductive Switching Waveforms