



# XTMF50N46E

## 500V N-ch Planar MOSFET

### Product Description

$BV_{DSS}$	500	V
$I_D$	46	A
$R_{DS(ON), Typ.}$	85	m $\Omega$

### General Features

- Advanced Planar Process
- $R_{DS(ON), typ.} = 85m\Omega @ V_{GS} = 10V$
- Low Gate Charge Minimize Switching Loss
- Rugged Poly silicon Gate Structure

### Applications

- BLDC Motor Driver
- Electric Welder
- High Efficiency SMPS

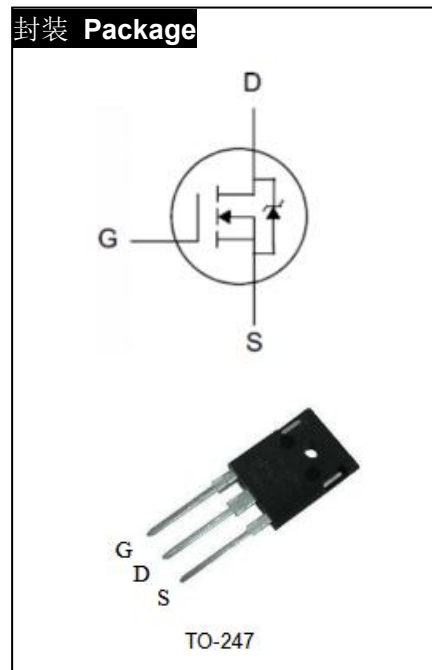

Device	Package	Marking
XTMF50N46E	TO-247	XTMF50N46E

### Absolute Maximum Ratings $T_j = 25^\circ\text{C}$

Symbol	Parameter	XTMF50N46E	Unit
$V_{DSS}$	Drain-to-Source Voltage	900	V
$V_{GSS}$	Gate-to-Source Voltage	$\pm 30$	
$I_D$	Continuous Drain Current	46	A
$I_{DM}$	Pulsed Drain Current at $V_{GS} = 10V$	180	
$E_{AS}$	Single Pulse Avalanche Energy	5000	mJ
$P_D$	Power Dissipation	540	W
	Derating Factor above $25^\circ\text{C}$	4.32	W/ $^\circ\text{C}$
$T_L$	Soldering Temperature Distance of 1.6mm from case for 10 seconds	300	$^\circ\text{C}$
$T_J \& T_{STG}$	Operating and Storage Temperature Range	-55 to 150	



Caution: Stresses greater than those listed in the “Absolute Maximum Ratings” may cause permanent damage to the device.

## Thermal Characteristics

Symbol	Parameter	XTMF50N46E	Unit
$R_{\theta JC}$	Thermal Resistance, Junction-to-Case	0.23	$^{\circ}C/W$
$R_{\theta JA}$	Thermal Resistance, Junction-to-Ambient	50	$^{\circ}C/W$

## Electrical Characteristics $T_j=25^{\circ}C$

### OFF Characteristics

Symbol	Parameter	Min	Typ	Max	Unit	Test Condition
$BV_{DSS}$	Drain-to-Source Breakdown Voltage	500	--	--	V	$V_{GS}=0V, I_D=250\mu A$
$I_{DSS}$	Drain-to-Source Leakage Current	--	--	5	uA	$V_{DS}=500V, V_{GS}=0V$
		--	--	500		$V_{DS}=400V, V_{GS}=0V, T_J=125^{\circ}C$
$I_{GSS}$	Gate-to-Source Leakage Current	--	--	+100	nA	$V_{GS}=+30V, V_{DS}=0V$
		--	--	-100		$V_{GS}=-30V, V_{DS}=0V$

### ON Characteristics

Symbol	Parameter	Min	Typ	Max	Unit	Test Condition
$R_{DS(ON)}$	Static Drain-to-Source On-Resistance <sup>[4]</sup>	--	85	100	m $\Omega$	$V_{GS}=10V, I_D=23A$
$V_{GS(TH)}$	Gate Threshold Voltage	2.0	--	4.0	V	$V_{DS}=V_{GS}, I_D=250\mu A$
gfs	Forward Transconductance <sup>[4]</sup>	--	32	--	S	$V_{DS}=25V, I_D=23A$



## Dynamic Characteristics

Symbol	Parameter	Min	Typ	Max	Unit	Test Condition
$C_{iss}$	Input Capacitance	--	6.8	--	nF	$V_{GS}=0V$ , $V_{DS}=25V$ , $f=1.0MHz$
$C_{rss}$	Reverse Transfer Capacitance	--	0.1	--		
$C_{oss}$	Output Capacitance	--	0.7	--		
$Q_g$	Total Gate Charge	--	138	--	nC	$V_{DD}=250V$ , $I_D=23A$ , $V_{GS}=0$ to $10V$
$Q_{gs}$	Gate-to-Source Charge	--	38	--		
$Q_{gd}$	Gate-to-Drain (Miller) Charge	--	27	--		

## Resistive Switching Characteristics

Symbol	Parameter	Min	Typ	Max	Unit	Test Condition
$t_{d(ON)}$	Turn-on Delay Time	--	25	--	ns	$V_{DD}=250V$ , $I_D=23A$ , $V_{GS}=10V$ $R_G=10\Omega$
$t_{rise}$	Rise Time	--	39	--		
$t_{d(OFF)}$	Turn-Off Delay Time	--	100	--		
$t_{fall}$	Fall Time	--	36	--		

## Source-Drain Body Diode Characteristics

Symbol	Parameter	Min	Typ	Max	Unit	Test Condition
$I_{SD}$	Continuous Source Current <sup>[4]</sup>	--	--	46	A	Integral pn-diode in MOSFET
$I_{SM}$	Pulsed Source Current <sup>[4]</sup>	--	--	180		
$V_{SD}$	Diode Forward Voltage	--	--	1.5	V	$I_S=46A$ , $V_{GS}=0V$
trr	Reverse recovery time	--	730	--	ns	$V_{GS}=0V$ , $I_F=46A$ , $di_F/dt=100A/\mu s$
Qrr	Reverse recovery charge	--	3.0	--	uC	

[1] Pulse width $\leq 380\mu s$ ; duty cycle $\leq 2\%$



# Typical Characteristics

Figure 1. Maximum Transient Thermal Impedance

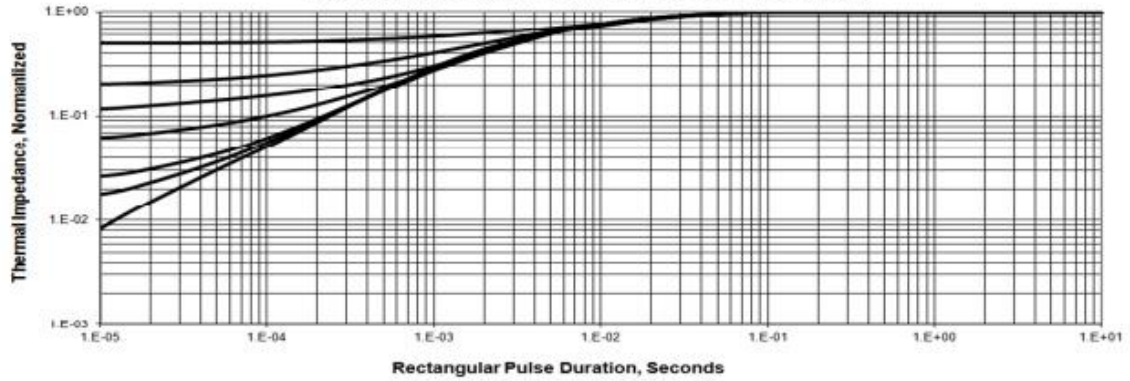

Figure 2 . Max. Power Dissipation vs Case Temperature

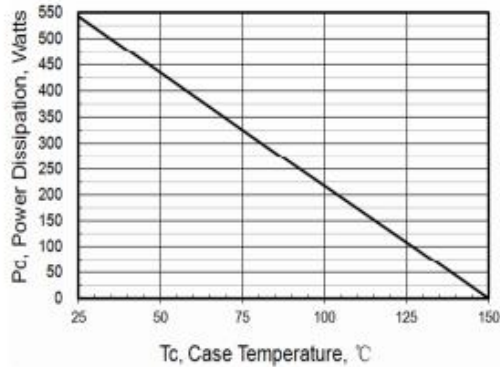

Figure 3 .Maximum Continuous Drain Current vs Tc

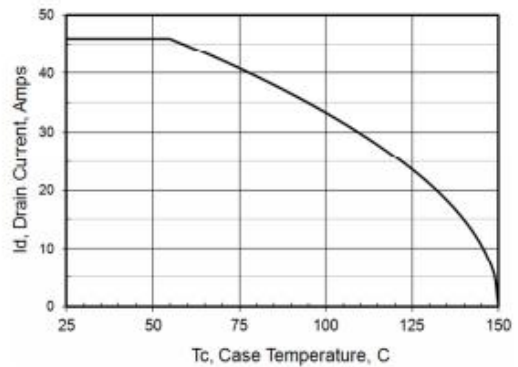

Figure 4. Typical Output Characteristics

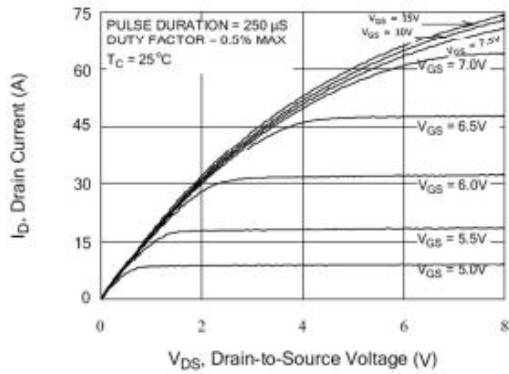
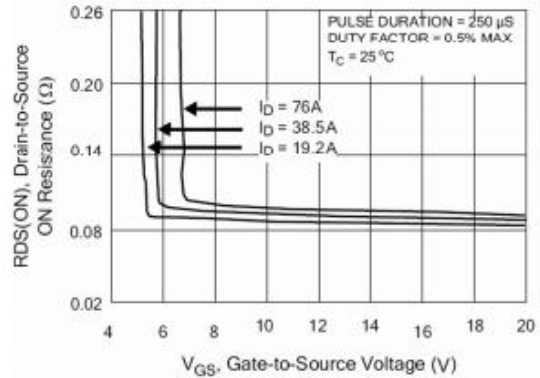

Figure5. Typical Drain-to-Source ON Resistance vs Gate Voltage and Drain Current





Typical Characteristics(Cont.)

Figure 6. Peak Current Capability

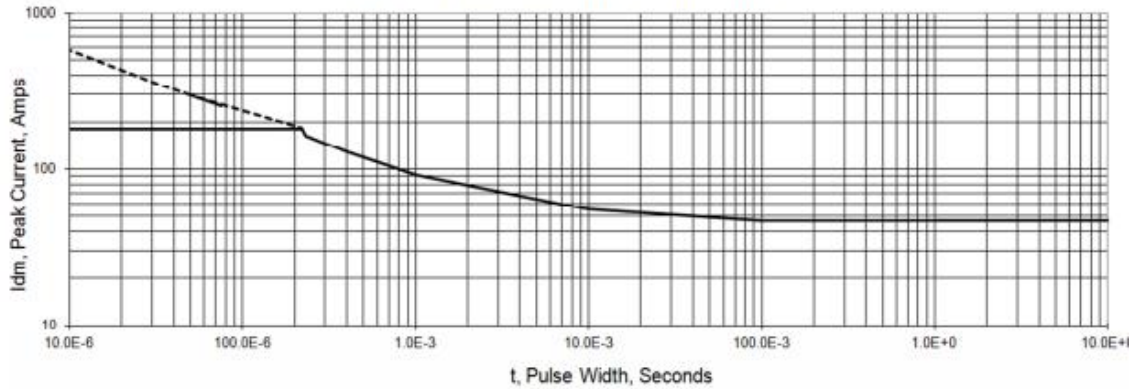

Figure 7. Typical Transfer Characteristics

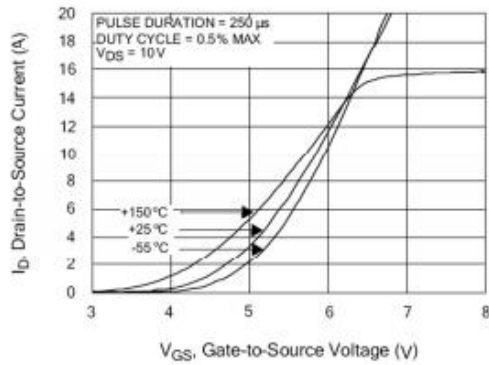

Figure 8. Unclamped Inductive Switching Capability

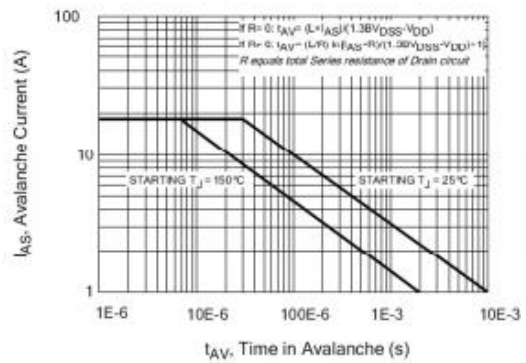

Figure 9. Typical Drain-to-Source ON Resistance vs Drain Current

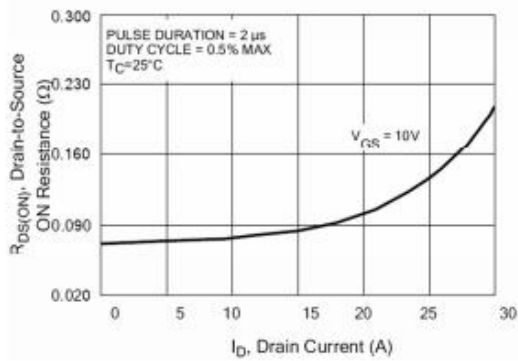
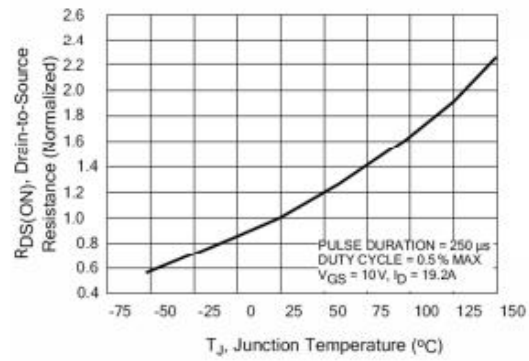

Figure 10. Typical Drain-to-Source ON Resistance vs Junction Temperature





### Typical Characteristics(Cont.)

Figure 11. Typical Breakdown Voltage vs Junction Temperature

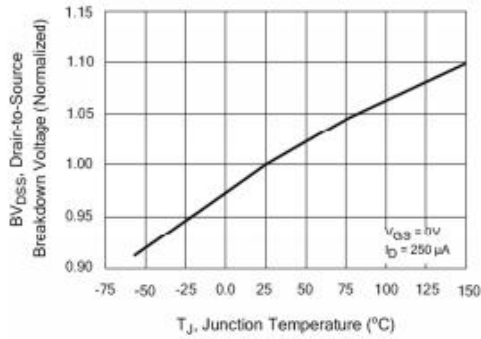

Figure 12. Typical Threshold Voltage vs Junction Temperature

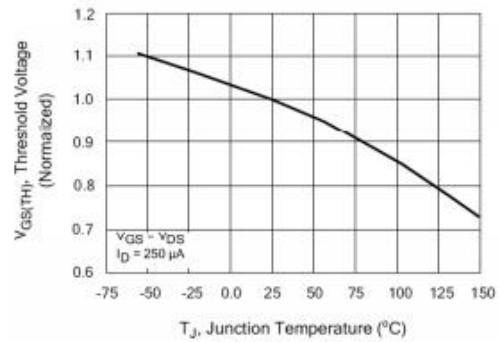

Figure 13. Maximum Forward Bias Safe Operating Area

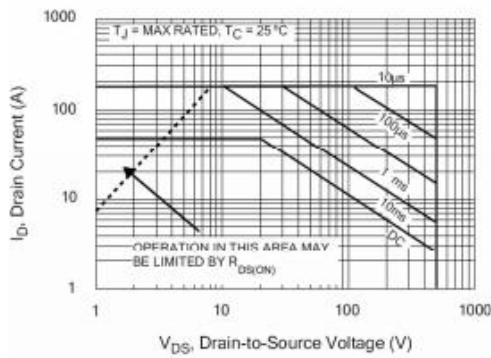

Figure 14. Typical Capacitance vs Drain-to-Source Voltage

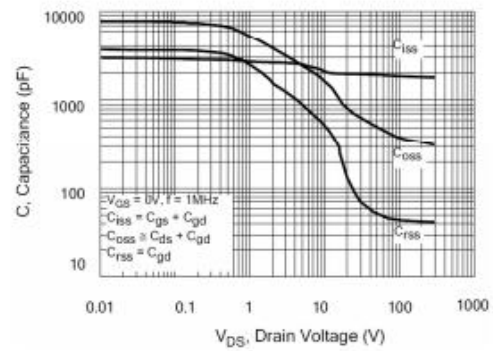

Figure 15. Typical Gate Charge vs Gate-to-Source Voltage

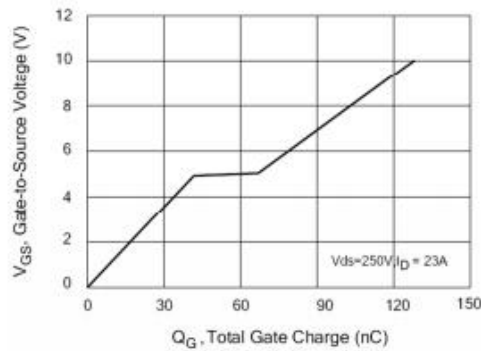
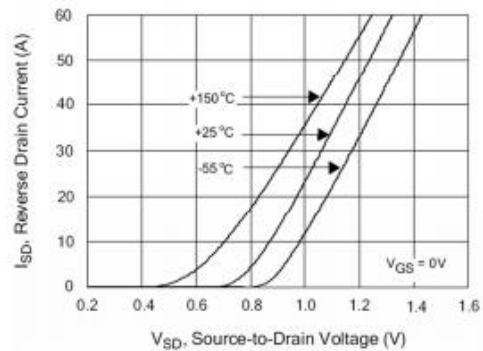

Figure 16. Typical Body Diode Transfer Characteristics





Test Circuits and Waveforms

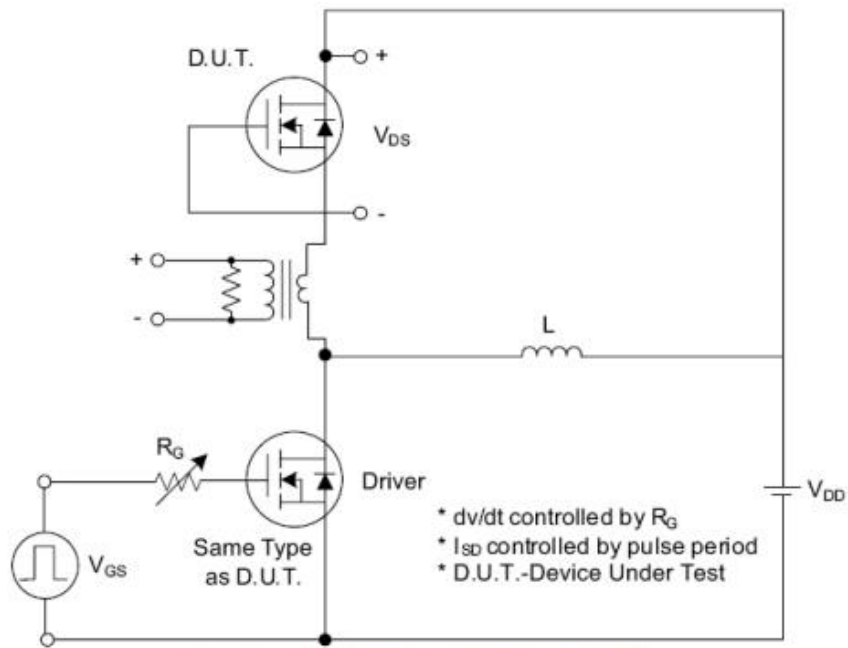

Fig. 1.1 Peak Diode Recovery dv/dt Test Circuit

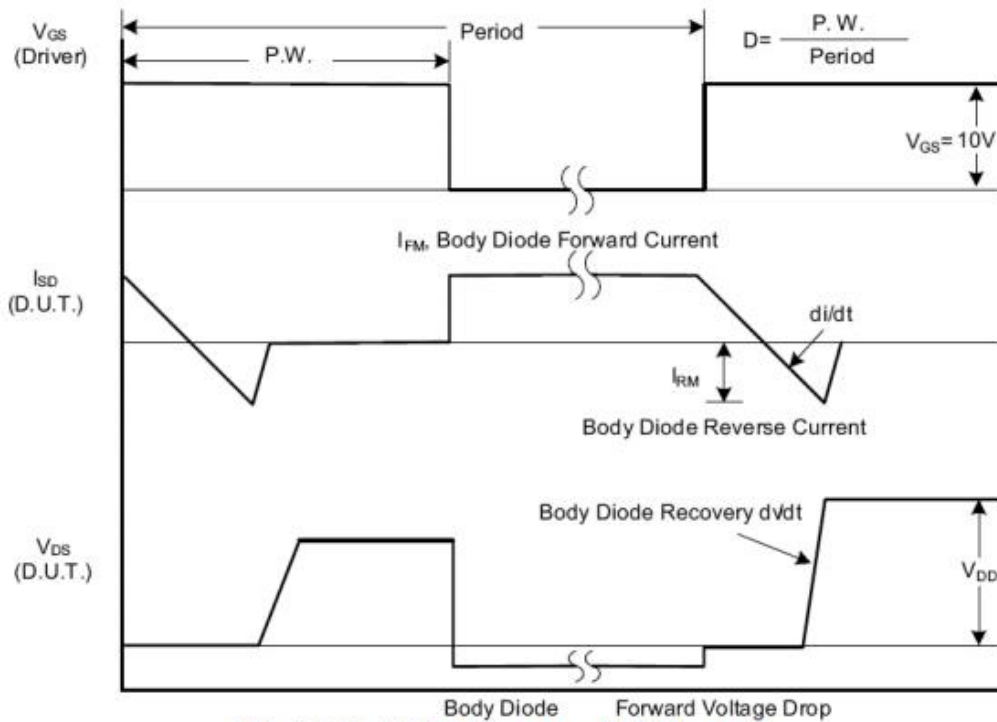

Fig. 1.2 Peak Diode Recovery dv/dt Waveforms



Test Circuits and Waveforms (cont.)

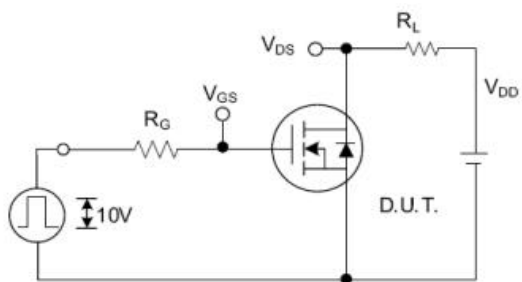

Fig. 2.1 Switching Test Circuit

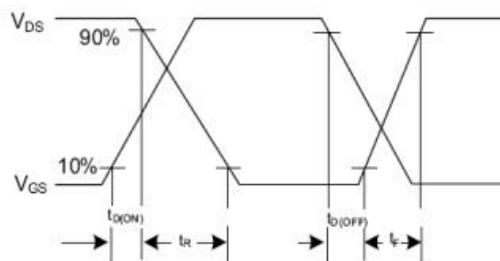

Fig. 2.2 Switching Waveforms

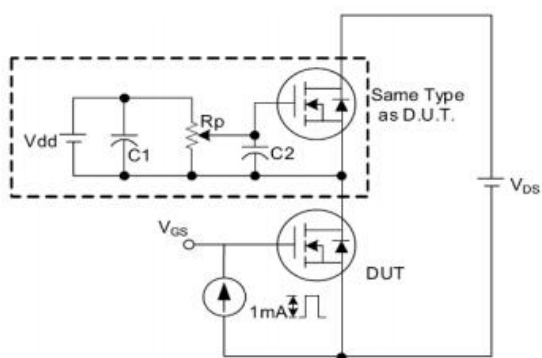

Fig. 3.1 Gate Charge Test Circuit

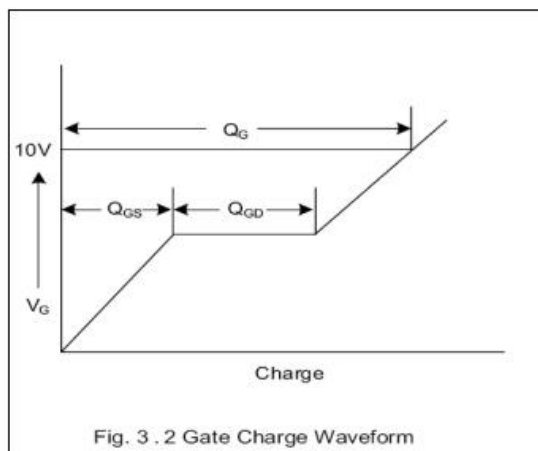

Fig. 3.2 Gate Charge Waveform

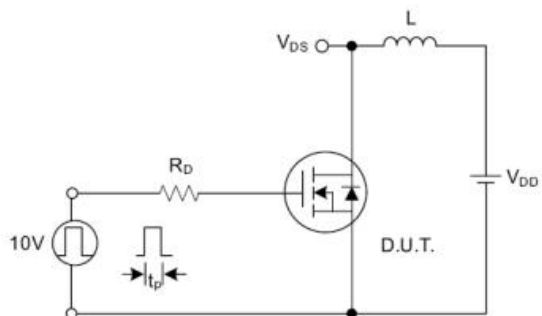

Fig. 4.1 Unclamped Inductive Switching Test Circuit

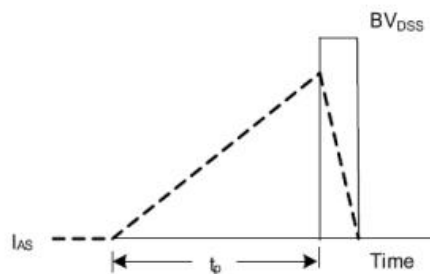

Fig. 4.2 Unclamped Inductive Switching Waveforms