



XTMT04N65D

40V N-Channel MOSFET

Product Description

| | | |
|-------------------|--------|----------|
| BV_{DSS} | 40 | V |
| I_D | 65 | A |
| $R_{DS(ON),Typ.}$ | 0.0075 | Ω |

General Features

- Proprietary New Planar Technology
- $R_{DS(ON),typ.}=7.5\text{ m}\Omega@V_{GS}=10V$
- Fast Recovery Body Diode
- Low Gate Charge Minimize Switching Loss

Applications

- Synchronous Rectification
- UPS Inverter

封装 Package

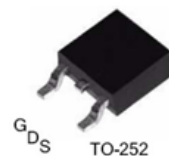
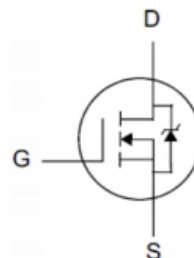

| Device | Package | Marking |
|------------|---------|------------|
| XTMT04N65D | TO-252 | XTMT04N65D |

Absolute Maximum Ratings $T_j=25^\circ\text{C}$

| Symbol | Parameter | Value | Unit |
|------------------|--|------------|------------------|
| V_{DSS} | Drain-to-Source Voltage | 40 | V |
| V_{GSS} | Gate-to-Source Voltage | ± 20 | |
| I_D | Continuous Drain Current | 65 | A |
| I_{DM} | Pulsed Drain Current at $V_{GS}=10V$ | 260 | |
| T_L | Soldering Temperature Distance of 1.6mm from case for 10 seconds | 300 | $^\circ\text{C}$ |
| $T_J \& T_{STG}$ | Operating and Storage Temperature Range | -55 to 150 | |

Caution: Stresses greater than those listed in the "Absolute Maximum Ratings" may cause permanent damage to the device.



Thermal Characteristics

| Symbol | Parameter | Value | Unit |
|-----------------|---|-------|---------------|
| $R_{\theta JC}$ | Thermal Resistance, Junction-to-Case | 0.89 | $^{\circ}C/W$ |
| $R_{\theta JA}$ | Thermal Resistance, Junction-to-Ambient | 75 | $^{\circ}C/W$ |

Electrical Characteristics $T_j=25^{\circ}C$

OFF Characteristics

| Symbol | Parameter | Min | Typ | Max | Unit | Test Condition |
|------------|-----------------------------------|-----|-----|------|------|---|
| BV_{DSS} | Drain-to-Source Breakdown Voltage | 40 | - | - | V | $V_{GS}=0V, I_D=250\mu A$ |
| I_{DSS} | Drain-to-Source Leakage Current | - | - | 1 | uA | $V_{DS}=40V, V_{GS}=0V$ |
| | | - | - | 100 | | $V_{DS}=32V, V_{GS}=0V, T_J=125^{\circ}C$ |
| I_{GSS} | Gate-to-Source Leakage Current | - | - | +100 | nA | $V_{GS}=+20V, V_{DS}=0V$ |
| | | - | - | -100 | | $V_{GS}=-20V, V_{DS}=0V$ |

ON Characteristics

| Symbol | Parameter | Min | Typ | Max | Unit | Test Condition |
|--------------|--------------------------------------|-----|------|-----|------------|-------------------------------|
| $R_{DS(ON)}$ | Static Drain-to-Source On-Resistance | - | 7.5 | 9 | m Ω | $V_{GS}=10V, I_D=30A$ |
| | | - | 10.7 | 14 | | $V_{GS}=4.5V, I_D=30A$ |
| $V_{GS(TH)}$ | Gate Threshold Voltage | 1.0 | - | 2.5 | V | $V_{DS}=V_{GS}, I_D=250\mu A$ |



Dynamic Characteristics

| Symbol | Parameter | Min | Typ | Max | Unit | Test Condition |
|-----------|-------------------------------|-----|------|-----|------|--|
| C_{iss} | Input Capacitance | - | 2255 | - | pF | $V_{GS}=0V$, $V_{DS}=20V$, $f=1.0MHz$ |
| C_{rss} | Reverse Transfer Capacitance | - | 149 | - | | |
| C_{oss} | Output Capacitance | - | 178 | - | | |
| Q_g | Total Gate Charge | - | 43 | - | nC | $V_{DD}=20V$, $I_D=30A$, $V_{GS}=0$ to 10V |
| Q_{gs} | Gate-to-Source Charge | - | 8 | - | | |
| Q_{gd} | Gate-to-Drain (Miller) Charge | - | 8 | - | | |

Resistive Switching Characteristics

| Symbol | Parameter | Min | Typ | Max | Unit | Test Condition |
|--------------|---------------------|-----|-----|-----|------|--|
| $t_{d(ON)}$ | Turn-on Delay Time | - | 14 | - | ns | $V_{DD}=20V$, $I_D=30A$, $V_{GS}=10V$ $R_g=3\Omega$ |
| t_{rise} | Rise Time | - | 6 | - | | |
| $t_{d(OFF)}$ | Turn-Off Delay Time | - | 50 | - | | |
| t_{fall} | Fall Time | - | 7 | - | | |

Source-Drain Body Diode Characteristics

| Symbol | Parameter | Min | Typ | Max | Unit | Test Condition |
|----------|--|-----|-----|-----|------|-------------------------------------|
| I_{SD} | Continuous Source Current ^[1] | - | - | 65 | A | Integral pn-diode in MOSFET |
| I_{SM} | Pulsed Source Current ^[1] | - | - | 260 | | |
| V_{SD} | Diode Forward Voltage | - | - | 1.2 | V | $I_S=30A$, $V_{GS}=0V$ |
| t_{rr} | Reverse Recovery Time | - | 21 | - | ns | $I_F=30A$, $di_F/dt=100A/\mu s$ |
| Q_{rr} | Reverse Recovery Charge | - | 12 | - | uC | |

[1] Pulse width $\leq 380\mu s$; duty cycle $\leq 2\%$



Test Circuits and Waveforms

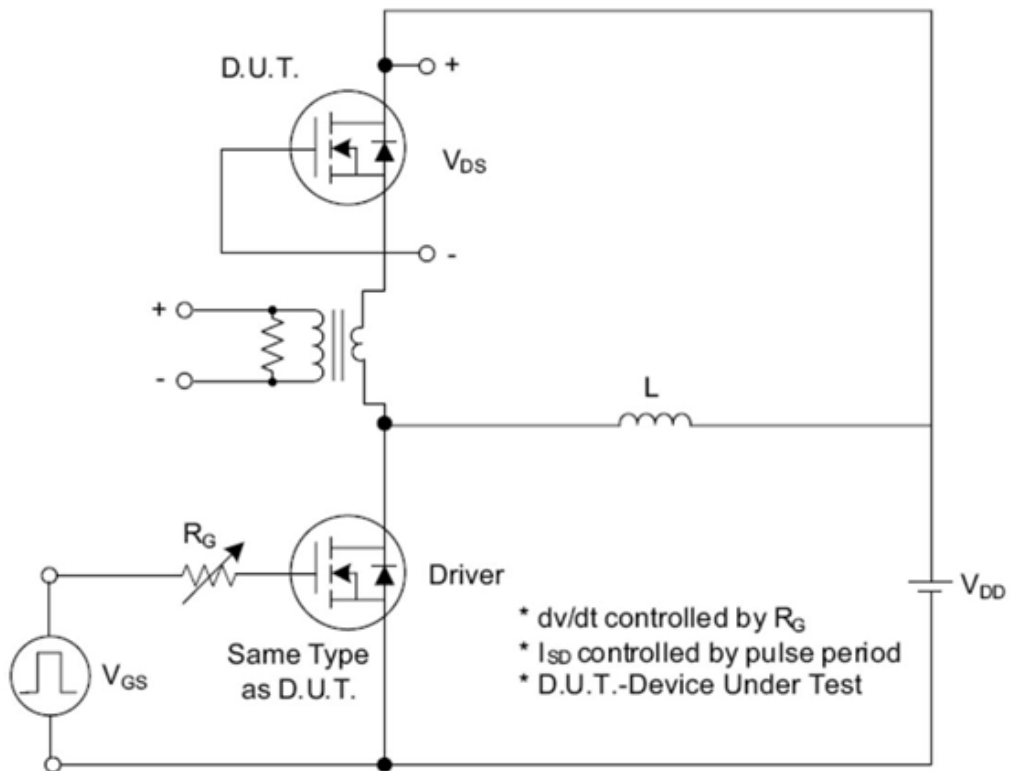

Fig. 1.1 Peak Diode Recovery dv/dt Test Circuit

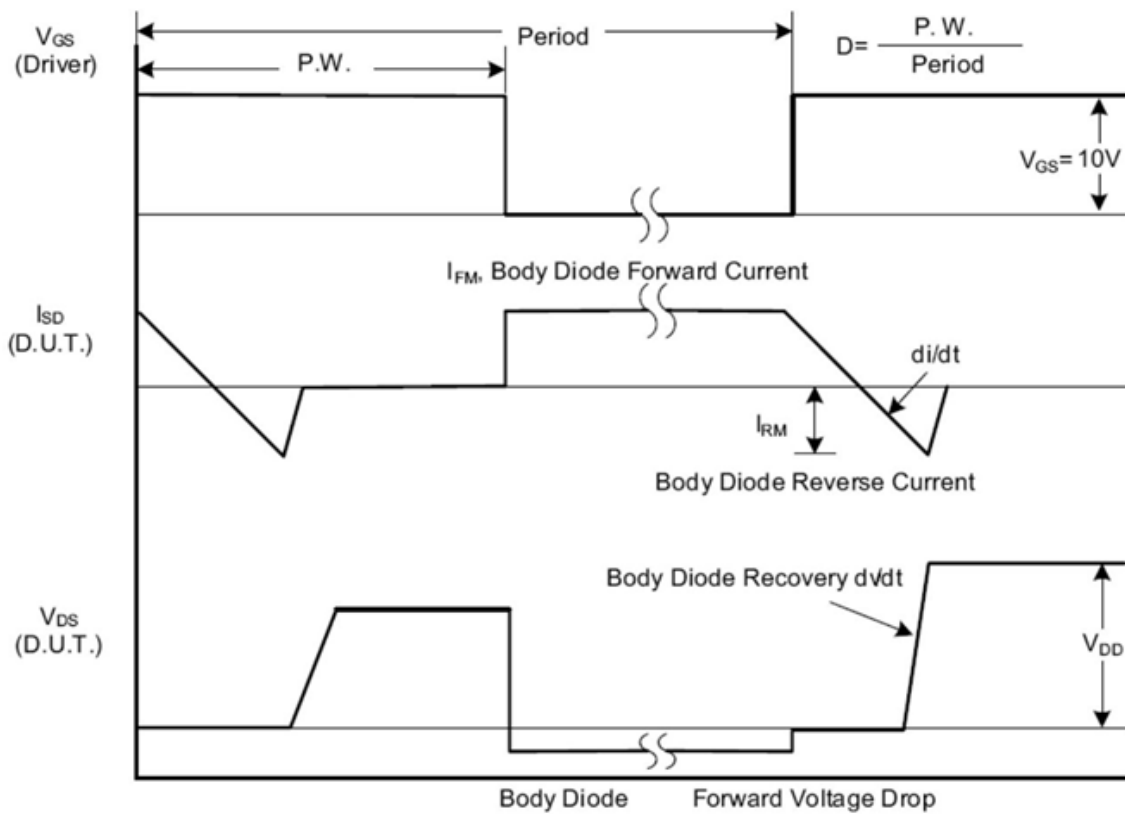

Fig. 1.2 Peak Diode Recovery dv/dt Waveforms



Test Circuits and Waveforms (Cont.)

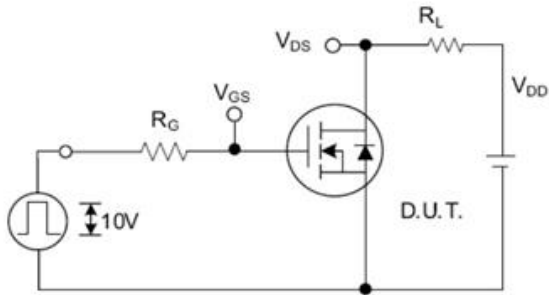

Fig. 2.1 Switching Test Circuit

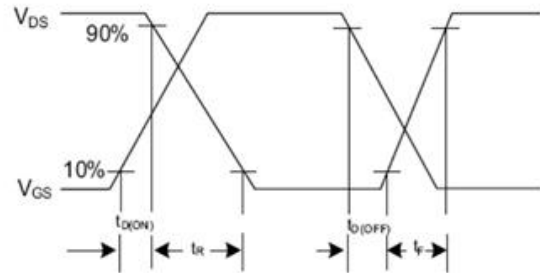

Fig. 2.2 Switching Waveforms

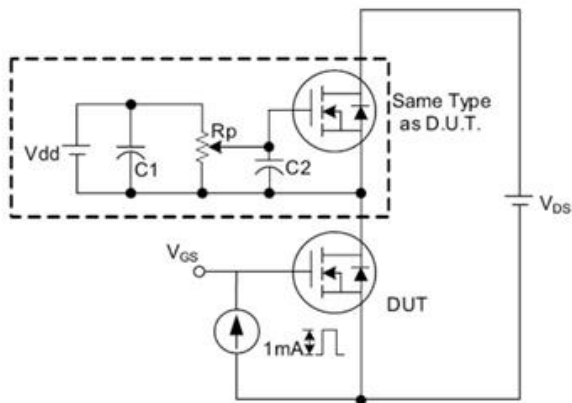

Fig. 3.1 Gate Charge Test Circuit

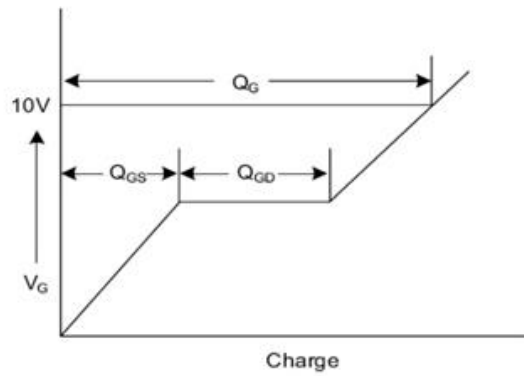

Fig. 3.2 Gate Charge Waveform

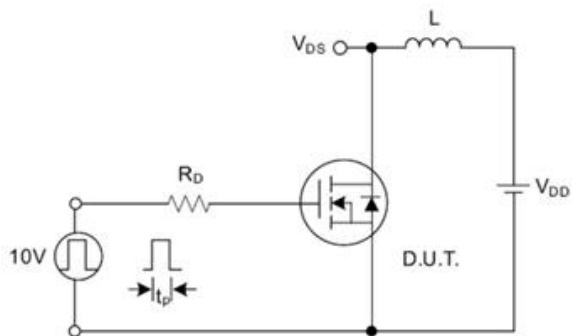

Fig. 4.1 Unclamped Inductive Switching Test Circuit

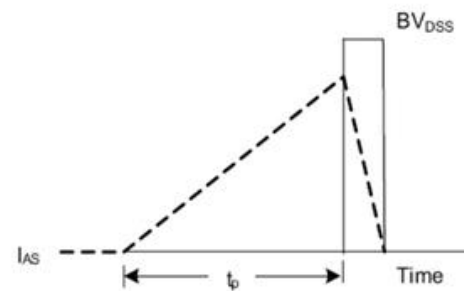

Fig. 4.2 Unclamped Inductive Switching Waveforms