



XTMF65N04FG

600V N-ch Planar MOSFET

Product Description

BV_{DSS}	650	V
I_D	4	A
$R_{DS(ON),Typ.}$	2.0	Ω

General Features

- RoHS Compliant
- $R_{DS(ON),typ.}=2.0\Omega@V_{GS}=10V$
- Fast Recovery Body Diode
- Low Gate Charge Minimize Switching Loss

Applications

- Adaptor
- Charger
- SMPS Standby Power

封装 Package

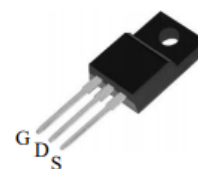
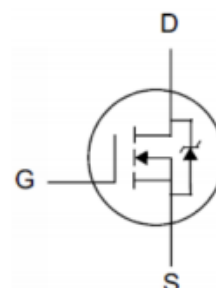

TO-220F

Device	Package	Marking
XTMF65N04FG	TO-220F	XTMF65N04FG

Absolute Maximum Ratings $T_j=25^\circ\text{C}$

Symbol	Parameter	Value	Unit
V_{DSS}	Drain-to-Source Voltage	650	V
V_{GSS}	Gate-to-Source Voltage	± 20	
I_D	Continuous Drain Current	4	A
I_{DM}	Pulsed Drain Current at $V_{GS}=10V$	16	
E_{AS}	Single Pulse Avalanche Energy	200	mJ
P_D	Power Dissipation	75	W
	Derating Factor above 25°C	0.60	$W/^\circ\text{C}$
T_L	Soldering Temperature Distance of 1.6mm from case for 10 seconds	300	$^\circ\text{C}$
$T_J \& T_{STG}$	Operating and Storage Temperature Range	-55 to 150	



Caution: Stresses greater than those listed in the “Absolute Maximum Ratings” may cause permanent damage to the device.

Thermal Characteristics

Symbol	Parameter	Value	Unit
$R_{\theta JC}$	Thermal Resistance, Junction-to-Case	1.67	$^{\circ}\text{C/W}$
$R_{\theta JA}$	Thermal Resistance, Junction-to-Ambient	62.5	$^{\circ}\text{C/W}$

Electrical Characteristics $T_j=25^{\circ}\text{C}$

OFF Characteristics

Symbol	Parameter	Min	Typ	Max	Unit	Test Condition
BV_{DSS}	Drain-to-Source Breakdown Voltage	650	-	-	V	$V_{GS}=0V, I_D=250\mu\text{A}$
I_{DSS}	Drain-to-Source Leakage Current	-	-	1	uA	$V_{DS}=650V, V_{GS}=0V$
		-	-	100		$V_{DS}=520V, V_{GS}=0V, T_j=125^{\circ}\text{C}$
I_{GSS}	Gate-to-Source Leakage Current	-	-	+100	nA	$V_{GS}=+30V, V_{DS}=0V$
		-	-	-100		$V_{GS}=-30V, V_{DS}=0V$

ON Characteristics

Symbol	Parameter	Min	Typ	Max	Unit	Test Condition
$R_{DS(ON)}$	Static Drain-to-Source On-Resistance	-	2.0	2.5	Ω	$V_{GS}=10V, I_D=2.0A$
$V_{GS(TH)}$	Gate Threshold Voltage	2.0	-	4.0	V	$V_{DS}=V_{GS}, I_D=250\mu\text{A}$
gfs	Forward Transconductance	-	3.5	-	S	$V_{DS}=15V, I_D=2A$



Dynamic Characteristics

Symbol	Parameter	Min	Typ	Max	Unit	Test Condition
C_{iss}	Input Capacitance	-	554	-	pF	$V_{GS}=0V$, $V_{DS}=25V$, $f=1.0MHz$
C_{rss}	Reverse Transfer Capacitance	-	2.2	-		
C_{oss}	Output Capacitance	-	50	-		
Q_g	Total Gate Charge	-	13	-	nC	$V_{DD}=520V$, $I_D=4A$, $V_{GS}=0$ to $10V$
Q_{gs}	Gate-to-Source Charge	-	2.7	-		
Q_{gd}	Gate-to-Drain (Miller) Charge	-	5.5	-		

Resistive Switching Characteristics

Symbol	Parameter	Min	Typ	Max	Unit	Test Condition
$t_{d(ON)}$	Turn-on Delay Time	-	14	-	ns	$V_{DD}=520V$, $I_D=4A$, $V_{GS}=10V$ $R_g=10\Omega$
t_{rise}	Rise Time	-	13	-		
$t_{d(OFF)}$	Turn-Off Delay Time	-	32	-		
t_{fall}	Fall Time	-	8	-		

Source-Drain Body Diode Characteristics

Symbol	Parameter	Min	Typ	Max	Unit	Test Condition
I_{SD}	Continuous Source Current ^[1]	-	-	4	A	Integral pn-diode in MOSFET
I_{SM}	Pulsed Source Current ^[1]	-	-	16		
V_{SD}	Diode Forward Voltage	-	-	1.5	V	$I_S=4A$, $V_{GS}=0V$
t_{rr}	Reverse Recovery Time	-	250	-	ns	$V_{GS}=0V$ $I_F=24$, $di/dt=100A/\mu s$
Q_{rr}	Reverse Recovery Charge	-	1.18	-	μC	

[1] Pulse width $\leq 380\mu s$; duty cycle $\leq 2\%$



Typical Characteristics

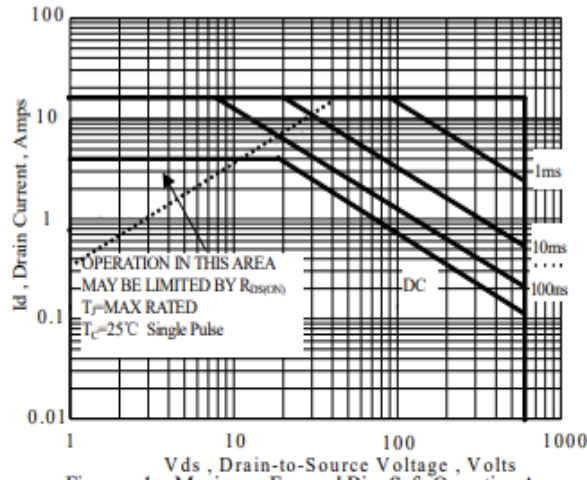

Figure 1 Maximum Forward Bias Safe Operating Area

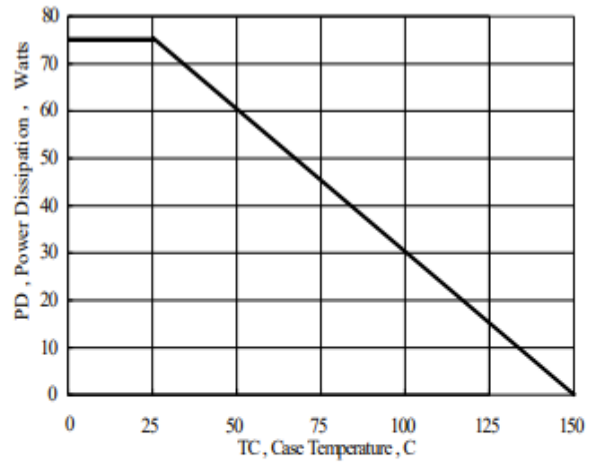

Figure 2 Maximum Power Dissipation vs Case Temperature

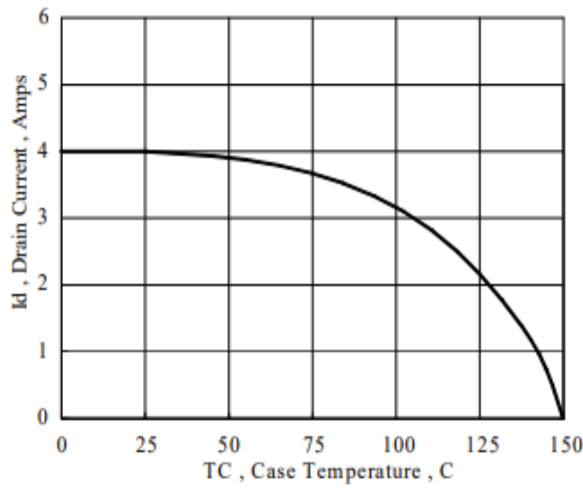

Figure 3 Maximum Continuous Drain Current vs Case Temperature

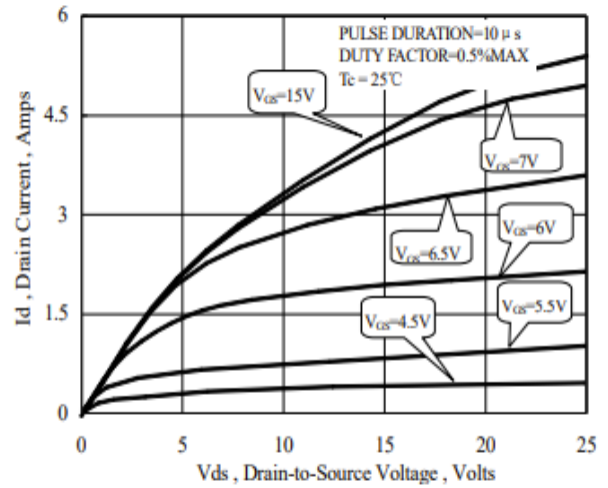

Figure 4 Typical Output Characteristics

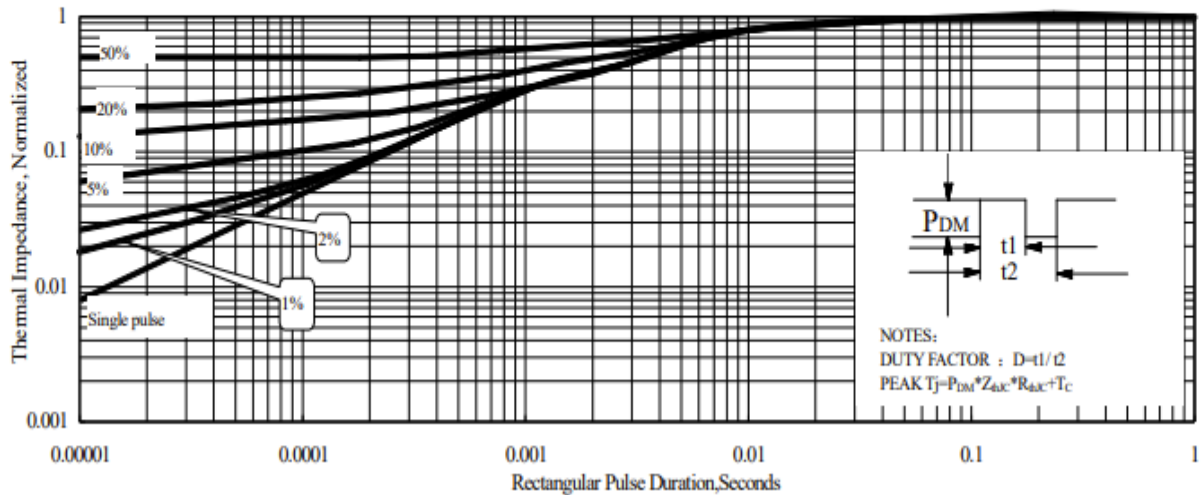

Figure 5 Maximum Effective Thermal Impedance , Junction to Case



Typical Characteristics(Cont.)

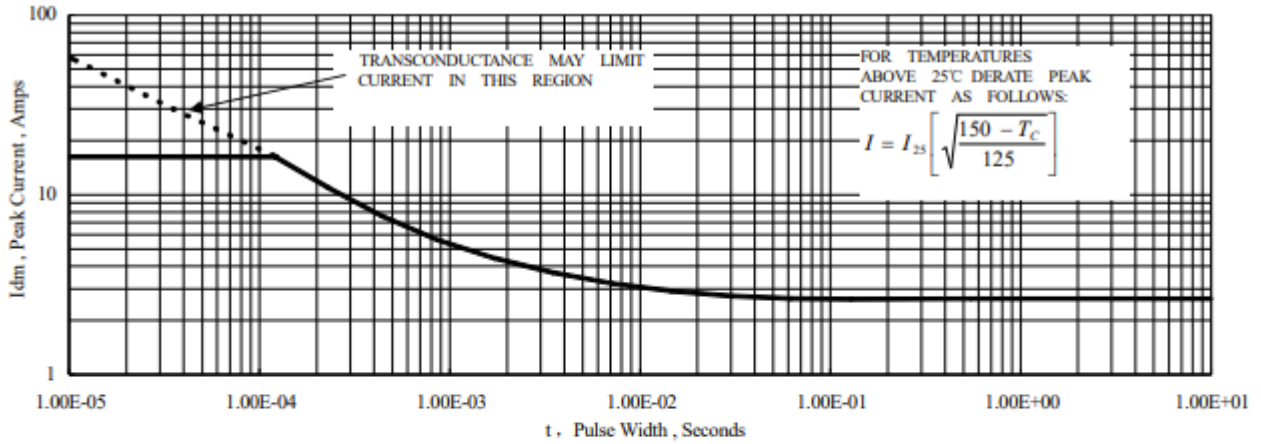

Figure 6 Maximum Peak Current Capability

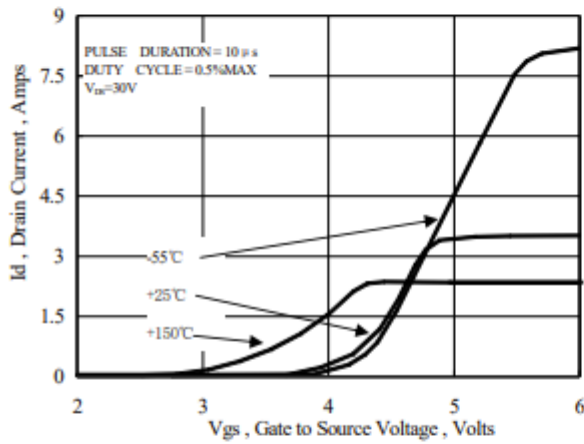

Figure 7 Typical Transfer Characteristics

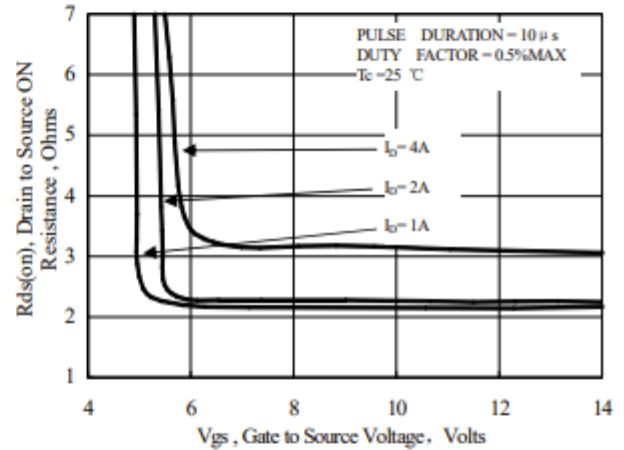

Figure 8 Typical Drain to Source ON Resistance vs. Gate Voltage and Drain Current

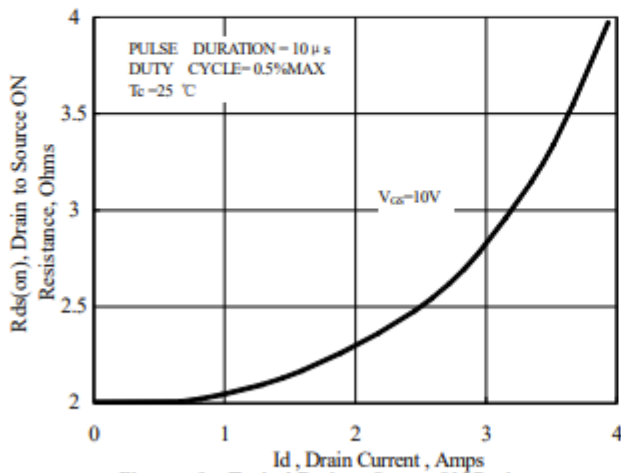

Figure 9 Typical Drain to Source ON Resistance vs. Drain Current

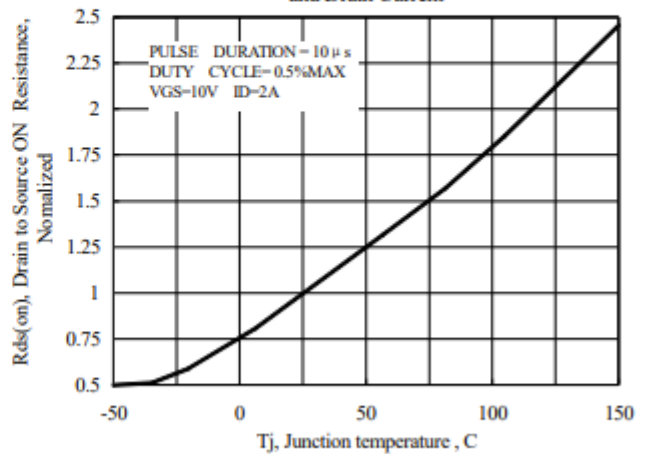

Figure 10 Typical Drain to Source on Resistance vs. Junction Temperature



Typical Characteristics(Cont.)

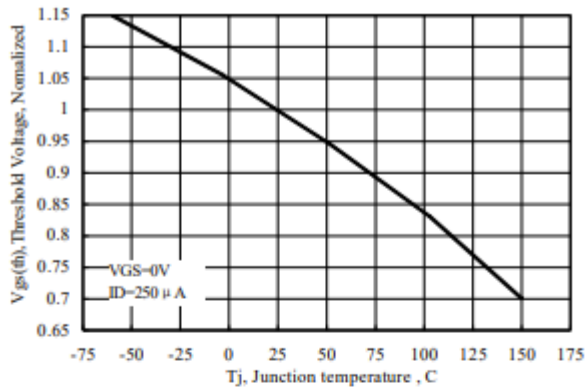

Figure 11 Typical Theshold Voltage vs Junction Temperature

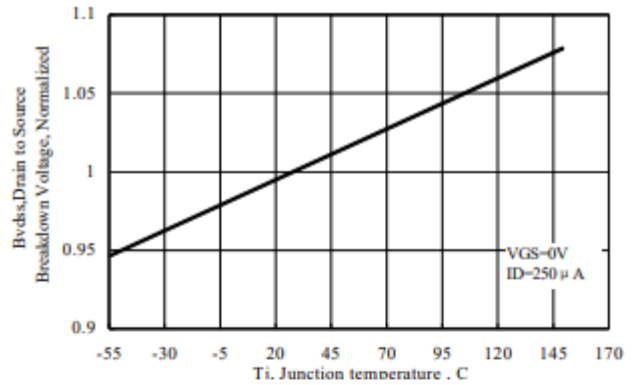

Figure 12 Typical Breakdown Voltage vs Junction Temperature

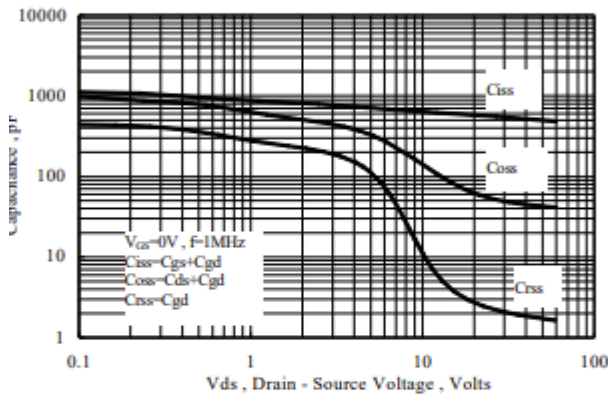

Figure 13 Typical Capacitance vs Drain to Source Voltage

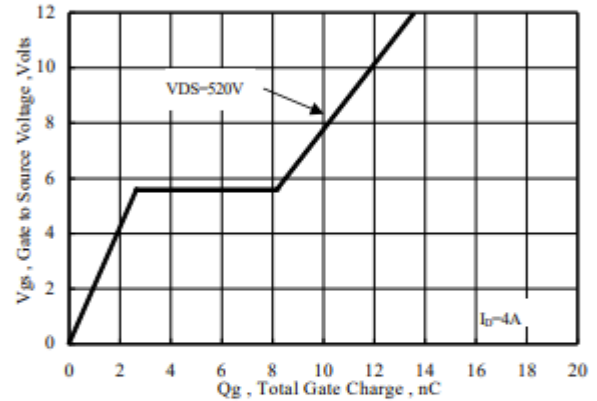

Figure 14 Typical Gate Charge vs Gate to Source Voltage

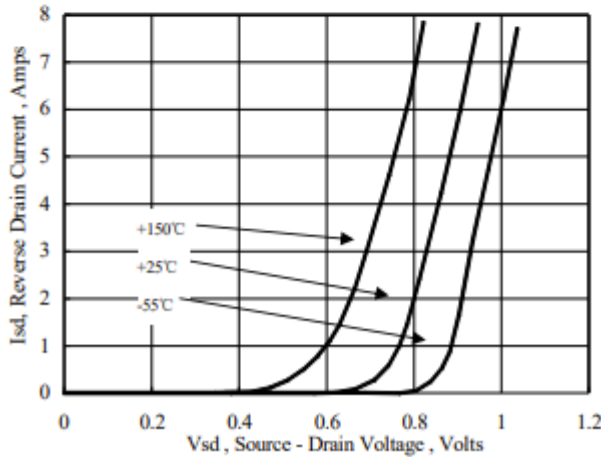

Figure 15 Typical Body Diode Transfer Characteristics

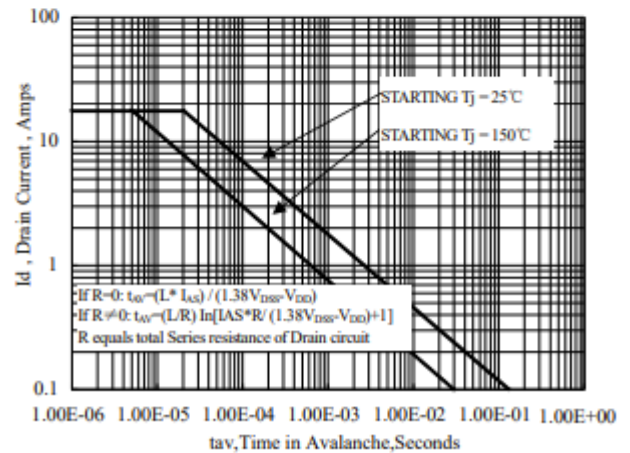

Figure 16 Unclamped Inductive Switching Capability



Test Circuits and Waveforms

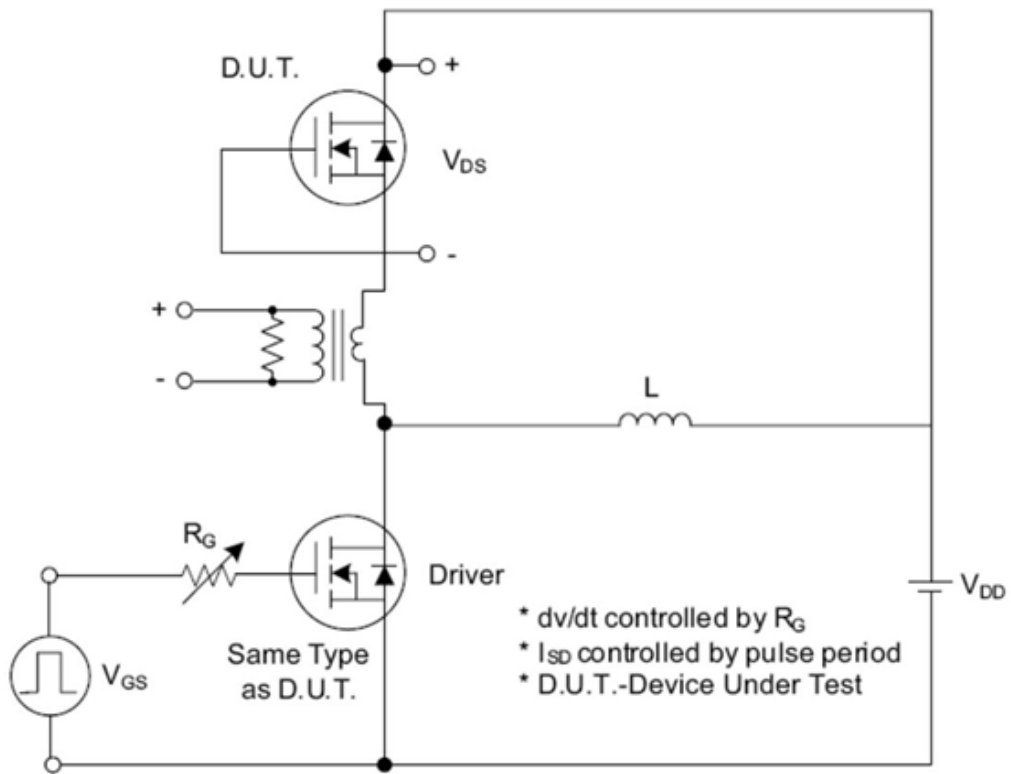

Fig. 1.1 Peak Diode Recovery dv/dt Test Circuit

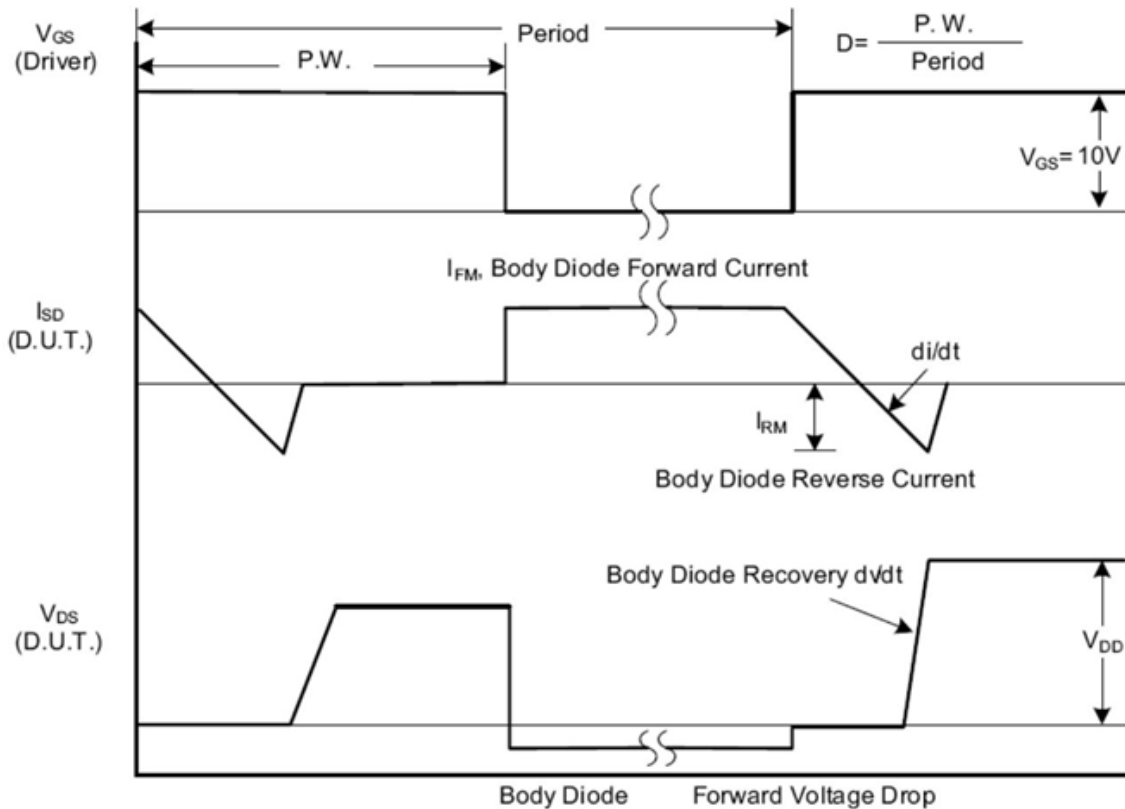

Fig. 1.2 Peak Diode Recovery dv/dt Waveforms



Test Circuits and Waveforms (Cont.)

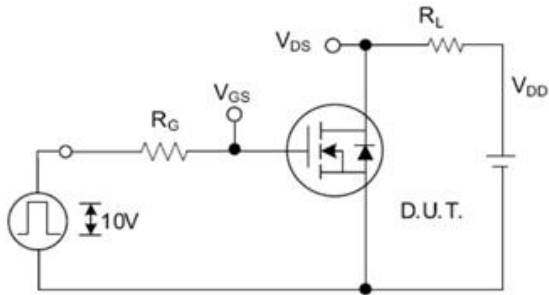

Fig. 2.1 Switching Test Circuit

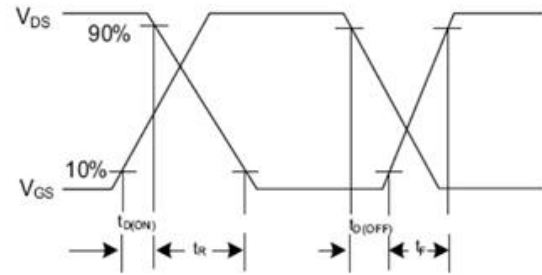

Fig. 2.2 Switching Waveforms

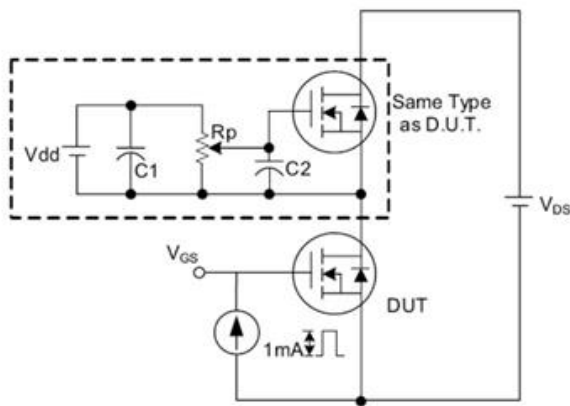

Fig. 3.1 Gate Charge Test Circuit

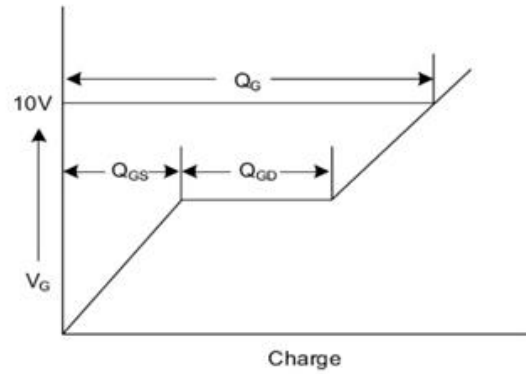

Fig. 3.2 Gate Charge Waveform

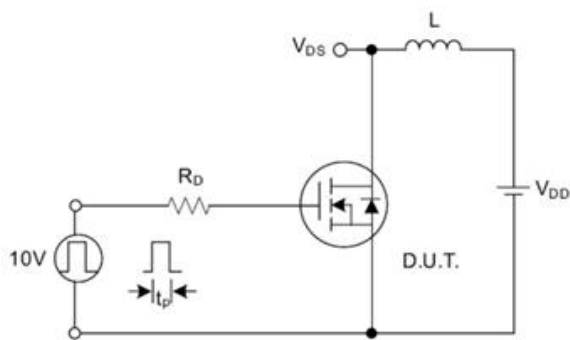

Fig. 4.1 Unclamped Inductive Switching Test Circuit

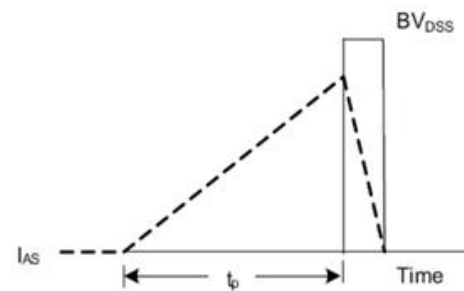

Fig. 4.2 Unclamped Inductive Switching Waveforms